

# installation and maintenance manual

for the installer and the user

## AURAX ECO

25 to 55 kW

---

HIGH EFFICIENCY REVERSIBLE AIR TO WATER HEAT PUMP

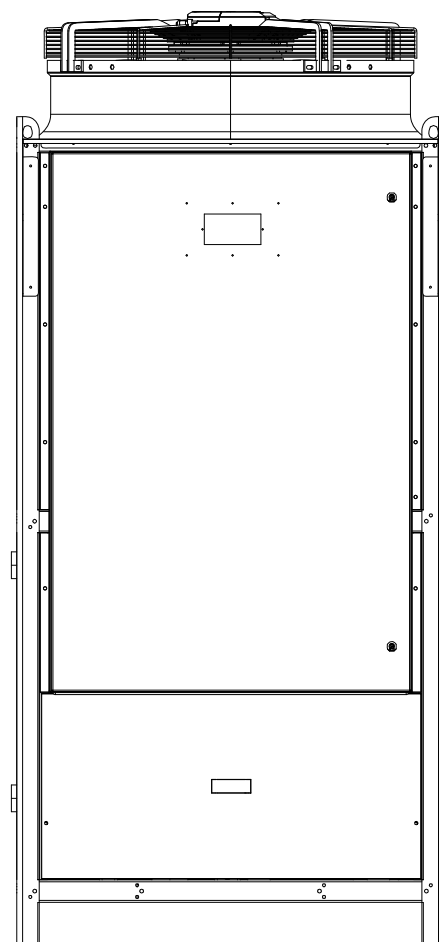

# TABLE OF CONTENTS

About our heat pumps:.....	G-3	Safety Instructions for the Electrical Connections.....	I-46
<b>GENERAL INFORMATION.....</b>	<b>G-4</b>	Power supply connection.....	I-46
Liabilities of the Manufacturer, the Installer and the End user .....	G-4	Terminal Block Connections .....	I-47
About this Manual .....	G-5	RS485 Serial Interface Card as Standard.....	I-48
Safety instructions .....	G-7	Installing a Remote Control Panel.....	I-49
Package Contents .....	G-8	Refrigerant Circuit Layout .....	I-50
Unit marking.....	G-8	<b>COMMISSIONING.....</b>	<b>I-52</b>
Emergency Stop.....	G-9	Safety Instructions Before Start-up .....	I-52
Restarting after an Emergency Stop.....	G-9	Filling the System.....	I-52
Health and Safety - Hazard and Prevention.....	G-10	Start-up and Commissioning .....	I-53
<b>PRODUCT DESCRIPTION.....</b>	<b>G-12</b>	<b>MAINTENANCE .....</b>	<b>I-54</b>
AURAX ECO .....	G-12	Safety Requirements for Maintenance .....	I-54
Options .....	G-13	Maintenance Requirements .....	I-55
Accessories.....	G-13	Specific Maintenance Tasks .....	I-56
Heat pump main components.....	G-14	Safety Requirements to Repair the Refrigerant Circuit.....	I-58
Control Panel and Main Functions .....	G-16	Repair of the Refrigerant Circuit.....	I-58
Symbols and Functions on the Control Panel ...	G-17	Discharging Refrigerant.....	I-59
<b>TECHNICAL SPECIFICATIONS .....</b>	<b>G-18</b>	Decommissioning.....	I-60
Clearances.....	G-19	Leak Test of the Refrigerant Circuit.....	I-60
Primary Circuit Performance Data.....	G-22	Charging Refrigerant.....	I-61
ErP Data.....	G-22	<b>ADDITIONAL INFORMATION FOR THE INSTALLER .....</b>	<b>I-62</b>
Refrigerant.....	G-23	Operation Modes.....	I-62
Electrical Data.....	G-23	Reset values .....	I-62
Primary Circuit Hydraulic Data.....	G-24	Set points .....	I-62
Options .....	G-24	Dynamic Set point (Weather Compensation) Function.....	I-63
4-pipe system.....	G-24	Operation of the Control Panel - Engineer Level.....	I-64
Sound Data for Super Silence Option.....	G-25	Troubleshooting .....	I-74
Limits of Operation .....	G-26		
Correction Factors .....	G-27		
Water Quality Guidelines for Air-to-Water Heat Pumps.....	G-28		
<b>INSTRUCTIONS FOR THE USER .....</b>	<b>G-29</b>		
Safety Instructions for the User .....	G-29		
Disposal of the Product at the end of Service Life..	G-29		
Operating the Controller - End User Level.....	U-30		
<b>PRODUCT INSTALLATION.....</b>	<b>I-34</b>		
Safety Instructions for the Installation .....	I-34		
Handling the Unit .....	I-35		
Unpacking the Unit.....	I-35		
Installing and Preparing the Unit.....	I-36		
Location of the unit.....	I-36		
Installing Anti-Vibration Dampers.....	I-38		
Opening and Closing the Access Doors .....	I-38		
Safety Instructions for the Hydraulic Connections.....	I-40		
Requirements for the Hydraulic Connections .....	I-41		
Flow Switch Installation .....	I-42		
Typical Hydraulic Connections - Primary.....	I-43		
System for the Production of DHW / Heating / Cooling .....	I-44		

Fig. 1.	Location of the main switch .....	G-9
Fig. 2.	Heat pump - Front view .....	G-14
Fig. 3.	Heat pump - Rear view.....	G-15
Fig. 4.	Control Panel.....	G-16
Fig. 5.	Handling the unit.....	I-35
Fig. 6.	Transporting the unit.....	I-35
Fig. 7.	Heat Pump Airflows.....	I-36
Fig. 8.	Anti-Snow Roof.....	I-37
Fig. 9.	Example of Wind Barrier.....	I-37
Fig. 10.	Installation of the Anti-Vibration Dampers.....	I-38
Fig. 11.	Water Filter Installation.....	I-41
Fig. 12.	Flow switch installation.....	I-42
Fig. 13.	Primary Circuit Components.....	I-43
Fig. 14.	Example diagram .....	I-44
Fig. 15.	Example diagram .....	I-45
Fig. 16.	Control Panel Connection to the Electronic Board...	I-49
Fig. 17.	Principle refrigeration diagram version 2 Pipes...	I-50
Fig. 18.	Principle refrigeration diagram version 4 Pipes....	I-51
Fig. 19.	Air vent.....	I-52
Fig. 20.	Dynamic set point diagram.....	I-63



The prefixes used in the page numbering indicate the following:

**G-** : General information

**U-** : Pages intended for the end user

**I-** : Pages intended **exclusively** for the qualified professional (e.g. installer)

## About our heat pumps:

### **Compliance**

Our heat pumps are compliant with the following directives and regulations:

- **ErP Energy Related Products Directive 2009/125/EC**
- **LVD Low Voltage Directive 2014/35/EU**
- **EMC Electromagnetic Compatibility Directive 2014/30/EU**
- **PED Pressure Equipment Directive 2014/68**
- **ROHS Restriction of Hazardous Substances Directive 2011/65/EU**

## GENERAL INFORMATION

### Liabilities of the Manufacturer, the Installer and the End user

#### Manufacturer

Our products are manufactured in compliance with the requirements of the applicable European Directives and standards, and are therefore delivered with all the required documentation and markings.

The quality of our products is essential to us, and we aim therefore at improving them continually. To this end, we reserve the right to change the technical characteristics and features of our products without prior notice. Please check for the latest revision of the manual on our website ([www.myaic.eu](http://www.myaic.eu)).

The manufacturer shall not be held liable for any malfunction of the product resulting from:

- ▶ The failure to comply with the safety and installation instructions provided herein,
- ▶ The failure to comply with the safety and operation instructions and recommendations provided herein,
- ▶ The failure to have the appliance maintained regularly,
- ▶ A modification of the appliance that is not approved by the manufacturer,
- ▶ The use of the product for any other purpose than its intended use,
- ▶ The use of components and accessories that are not approved by the manufacturer.

#### Installer

The installer is responsible for the correct installation, and commissioning of the appliance according to:

- ▶ The instructions and recommendations provided herein,
- ▶ The applicable regulations and standards,

The installer shall provide the end-user with:

- ▶ Any relevant explanation about the operation of the appliance and the heating system as well as the safety devices that are provided,

- ▶ Any instruction regarding periodic checks to be performed and possible anomaly to be reported,
- ▶ All the documentation delivered with the appliance and installed accessories.

The installer shall also inform the end-user of the necessity to have the appliance checked and maintained regularly by a qualified professional.

#### End-user

To ensure the best performances and safety of the appliance, the end-user shall:

- ▶ Make sure that the appliance is installed, commissioned and adjusted by a qualified professional,
- ▶ Make sure that the appliance is checked and maintained regularly by a qualified professional,
- ▶ Comply with all the instructions and recommendations provided in the appliance documentation,
- ▶ Make sure to receive from the installer all the necessary explanations related to the operation of the appliance and the safety devices,
- ▶ Make sure to receive from the installer all the appliance and accessories documentation,
- ▶ Keep all the appliance documentation in a safe place for future use.

The end-user shall use the product for its intended use.



- ▶ ***Should the installer or the end user not comply with the instructions and requirements stated in this manual, the warranty will be void.***

- ▶ ***For more information on the warranty terms and conditions, please connect to our website ([www.myaic.eu](http://www.myaic.eu))***



About this Manual

This documentation is part of the product. It will be handed over to the end-user who will keep it, with all the other applicable documents, in a safe place and readily available for use.

Before installing, operating or maintaining the unit, please carefully read this manual and all the applicable documents provided with the components and accessories. They contain essential safety information.

Safety message symbols



Indicates an essential instruction which, if not followed, can result in a hazardous situation that can cause serious damage to equipment and/or injuries or death.



Indicates an essential instruction in relation with the presence of electrical power and a danger of electrical shock.



Indicates an important instruction which, if not followed, could result in a hazardous situation that could cause damage to equipment and/or injuries.



Indicates important information.

Safety-related symbols



High Voltage - danger of electric shock.



Moving parts - risk of being crushed or torn.



Hot surface - risk of burns.



Sharp surface - risk of cuts.



Sharp elements - risk of injury or cut.



Dangerous substance - risk of damage or injuries.



Fire hazard



Wear safety shoes



Wear safety gloves



Wear safety glasses



Wear ear protections



Wear respiratory protection



Use fire-fighting equipment

Operation-related symbols



Ground / Earth.



The electrical supply to the appliance must be activated/deactivated through the external circuit breaker or the power supply cable must be connected/disconnected.

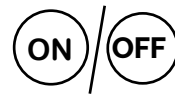

The unit must be started/stopped using the ON/OFF function of the control panel.



The refrigerant circuit must be full/empty of refrigerant.



The water circuit must be full of water/empty.

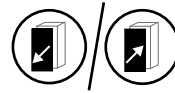

The access panel(s) of the appliance must be open/closed.

Symbols on the Packaging

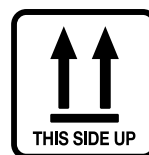

Labels on the appliance

**R454B**

Indicates the type of refrigerant used in the heat pump.



General safety sticker indicating main safety requirements and mandatory periodic maintenance tasks.

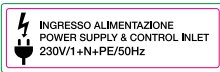

Indicates the location of the power supply connection and its characteristics.



Indicates the supply (outlet) circuit connection for Domestic Hot Water



Indicates the return (inlet) circuit connection for Domestic Hot Water



Indicates the supply (outlet) circuit connection for heating (primary) water



Indicates the return (inlet) circuit connection for heating (primary) water



Indicates where an air vent is located



Indicates where to connect the flow switch

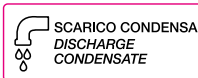

Indicates the condensate drain connection



Indicates a circuit that needs to be disconnected before maintenance or repair

## Safety instructions



### THIS UNIT CONTAINS REFRIGERANT R454B AND OIL WHICH ARE POTENTIALLY HAZARDOUS TOXIC SUBSTANCES

- ▶ Use care when handling these substances - make sure to wear protective personal equipment.
- ▶ Avoid contact with the eyes and the skin.
- ▶ Ensure correct ventilation to avoid refrigerant vapour concentrations close to the ground.
- ▶ Avoid contact with open flames or hot surfaces, which could cause the decomposition into toxic and irritating products.
- ▶ In case of oil leak or spillage, contain with sand or other suitable absorbent material. Do not allow the refrigerant to flow into drains, sewers or basement, where vapour could form.
- ▶ Follow the safety instructions and emergency procedures contained in this manual.
- ▶ In case of absolute necessity, perform an emergency stop as instructed in this manual.



- ▶ This product is intended exclusively for heating, cooling and domestic hot water production.
- ▶ Any use not specified in this manual is prohibited.
- ▶ This unit must be installed according to the applicable local regulations and standards.
- ▶ Make sure to wear protective personal equipment (respiratory protection, gloves, safety glasses, etc.) to carry out cleaning and maintenance tasks.
- ▶ Any modification to the unit and its components is strictly forbidden without the prior written consent of the manufacturer.
- ▶ If components need to be replaced, only genuine factory parts or components approved by the manufacturer must be used.



- ▶ When working on the unit and the system, make sure to use the appropriate tools to avoid damaging the pipes and components.

- ▶ Do not use the unit in excessively dusty, aggressive or explosive atmospheres, or in environments where there are heavy vibrations or electromagnetic fields.



- ▶ When unpacking the unit, check the integrity and condition of the packaging and that all the components and accessories described in the packing list are present. Contact your supplier in case of problem.
- ▶ When discarding the packaging, do not contaminate the environment. Dispose of it according to the applicable local regulations on recycling.

Identification of committed fluid type:  
**R454B**

*Chemical formula/composition:*

- ▶ Difluoromethane (HFC-32) 67.9-69.9%  
CAS No: 000075-10-5;
- ▶ Tetrafluoropropene (HFC-1234yf) 30.1-32.1% CAS No: 000754-12-1.

## GENERAL INFORMATION



### Package Contents

- ▶ An Aurax ECO Heat pump,
- ▶ An outdoor temperature sensor (to be installed)
- ▶ A flow switch (Refer to **"Flow Switch Installation"** on page I-42)
- ▶ An Installation and Maintenance manual,
- ▶ A set of documentation, containing wiring diagrams and a declaration of conformity.

Refer to **"Unpacking the Unit"** on page I-35 for the complete unpacking and installation instructions.

### Unit marking

The data plate is located in front of the heat pump.

				Manufacturer: Frost Italy S.r.l. Via Lago di Trasimeno n.46 36015 Schio -Vi-Italy			
<b>N° SERIE</b> SERIAL NUMBER / NUMÉRO DE SÉRIE							
<b>ANNO</b> YEAR / ANNÉE			<b>MODEL: AURAX ECO 55.1</b>				
<b>POTENZA FRIGORIFERA</b> (COOLING CAPACITY/PUISSANCE FRIGORIFIQUE)		49,4	[kW]	GWP (AR5)	466		
<b>POTENZA TERMICA</b> (HEATING CAPACITY/PUISSANCE THERMIQUE)		55,5	[kW]	REFR. CLASS	A2L		
<b>POTENZA ELETTRICA MASSIMA</b> (MAX ABSORBED POWER/PUISSANCE ABSORBÉE MAX)		26,31	[kW]	PED GROUP	1		
<b>CORRENTE ELETTRICA MASSIMA</b> (MAX OPERATING CURRENT/INTENSITÉ MAX DE FONCT.)		42,6	[A]	PED CAT.	III		
<b>CORRENTE DI SPUNTO</b> (STARTUP CURRENT/COURANT DE DÉMARRAGE)		154	[A]	PS_HP [bar]	45		
<b>CARICA DI REFRIGERANTE</b> (REFRIGERANT CHARGE/CHARGE DE RÉFRIGÉRANT)		12	[kg]	PS_LP [bar]	30		
<b>tCO<sub>2</sub></b> (tCO <sub>2</sub> /tCO <sub>2</sub> )		5,592	[t]	TS_HP [°C]	-10/120		
<b>PESO</b> (WEIGHT/POIDS)		575	[kg]	TS_LP [°C]	-25/20		
<b>TIPO DI ALIMENTAZIONE</b> (POWER SUPPLY TYPE/TYPE D'ALIMENTATION EL.)		400/50/3+N+PE V/Hz/~		REFRIGERANT	R454B		
CONTIENE GAS FLUORURATI AD EFFETTO SERRA DISCIPLINATI DAL PROTOCOLLO DI KYOTO CONTAINS FLUORINATED GREENHOUSE GASES GOVERNED BY THE KYOTO PROTOCOL - CONTIENT DES GAZ À EFFET DE SERRE FLUORÉS RÉGÉS PAR LE PROTOCOLE DE KYOTO							

## Emergency Stop

The emergency stop allows the unit to be stopped in the shortest possible time.

If the need arises to activate this procedure, proceed as follows:

- ▶ Turn the main switch (1) (yellow and red) to the OFF position (horizontal); this immediately stops the unit by deactivating the power supply to the unit.
- ▶ Call your installer to troubleshoot the system and restart the unit.

## Restarting after an Emergency Stop



- ▶ **This procedure can only be performed by qualified personnel.**
- ▶ **Before restarting and providing power supply to the unit, make sure that the reason/problem that initiated the emergency stop is found/corrected.**

To reset the unit after an emergency stop, proceed as follows :

- ▶ Turn the main switch (1) to the ON position (vertical); this action does not restart the unit but restores power supply to the unit.
- ▶ Perform the start up procedure of the unit, refer to **"Start-up and Commissioning"** on page I-53I-52.

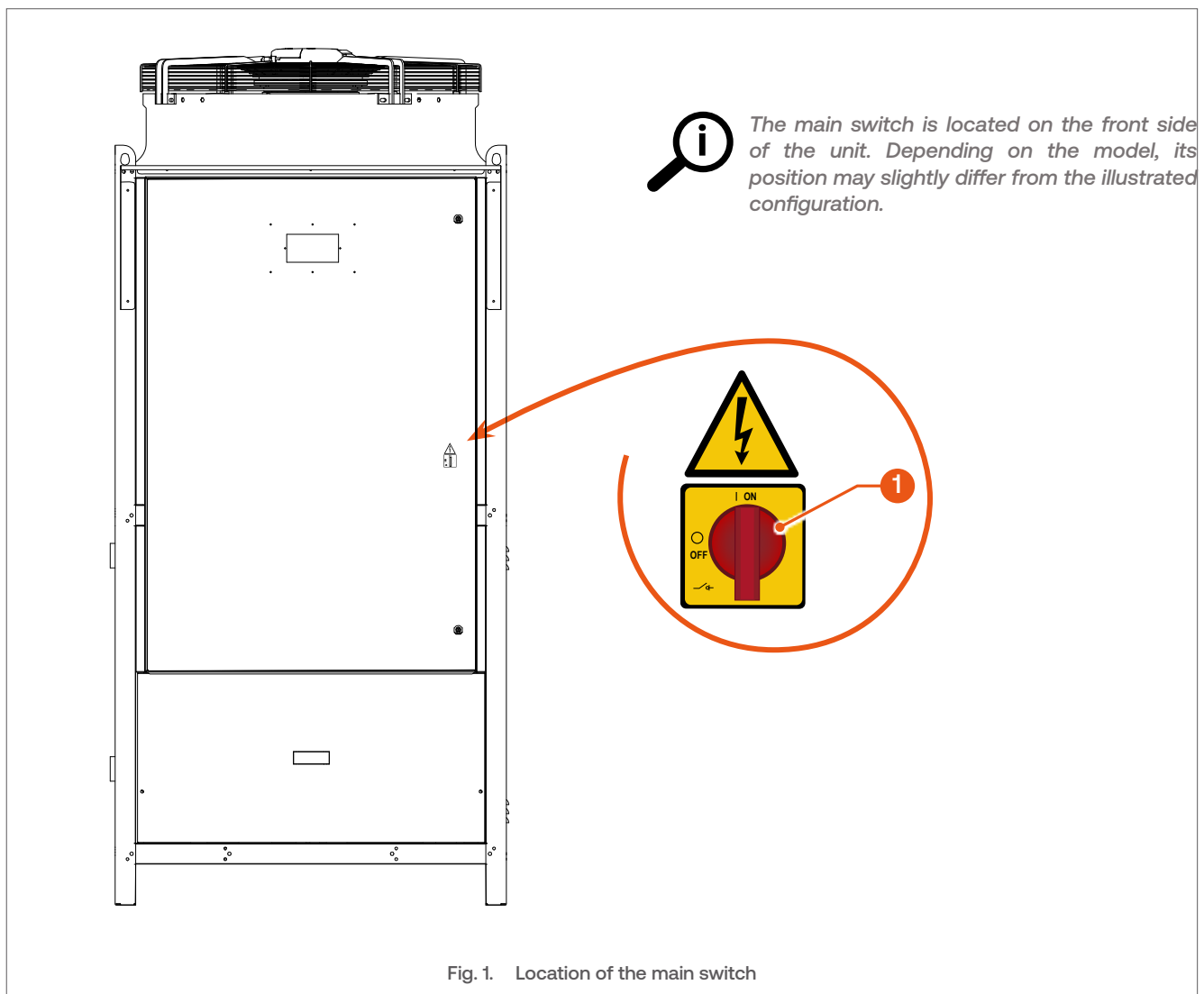



















Fig. 1. Location of the main switch

# GENERAL INFORMATION

## Health and Safety - Hazard and Prevention

Danger	Location	Potential Injuries	Prevention	First Aid
	Heat exchanger fins	<ul style="list-style-type: none"> <li>▶ Cuts</li> <li>▶ Hand injuries</li> </ul>		
	Fan and fan grids	<ul style="list-style-type: none"> <li>▶ Cuts</li> <li>▶ Hand/eye injuries</li> <li>▶ Broken bones</li> </ul>	  <p>Do not put objects through the protection grids</p>	<ul style="list-style-type: none"> <li>▶ Clean the wounds with disinfectant</li> <li>▶ Dress the wounds</li> <li>▶ In case of severe injuries, seek medical assistance</li> </ul>
	<ul style="list-style-type: none"> <li>▶ Compressors</li> <li>▶ Discharge pipes</li> </ul> Low pressure safety valve (refrigerant circuit)	<ul style="list-style-type: none"> <li>▶ Burns (contact with hot surface)</li> <li>▶ Frostbites (contact with refrigerant)</li> <li>▶ Poisoning (contact with skin or eyes, inhalation or ingestion)</li> </ul>	   <p>Check the pressure</p>	<p><b>In case of inhalation:</b></p> <ul style="list-style-type: none"> <li>▶ Move the person away from the source of exposure, keep them warm and let them rest</li> <li>▶ Administer oxygen if necessary</li> <li>▶ Attempt artificial respiration if breathing has stopped or shows signs of stopping</li> <li>▶ If the heart stops, perform external heart massage</li> <li>▶ Seek medical assistance</li> </ul> <p><b>In case of contact with the skin:</b></p> <ul style="list-style-type: none"> <li>▶ Wash immediately with lukewarm water</li> <li>▶ Thaw tissue using water</li> <li>▶ Remove contaminated clothing. Clothing may stick to the skin in case of frostbite</li> <li>▶ If irritation, swelling or blisters appear, seek medical assistance</li> </ul> <p><b>In case of contact with the eyes:</b></p> <ul style="list-style-type: none"> <li>▶ Rinse immediately using an eyewash or clean water, keeping eyelids open, for at least ten minutes</li> <li>▶ Seek medical assistance</li> </ul> <p><b>In case of Ingestion</b></p> <ul style="list-style-type: none"> <li>▶ Do not induce vomiting</li> <li>▶ If the injured person is conscious, rinse their mouth with water and make them drink 200-300 ml of water</li> <li>▶ Seek immediate medical assistance</li> </ul> <p><b>Do not administer adrenaline or similar sympathomimetic drugs following exposure, due to the risk of cardiac arrhythmia</b></p>
	High pressure safety valve (refrigerant circuit)	<ul style="list-style-type: none"> <li>▶ Burns (heat/contact with refrigerant or hydraulic oil)</li> <li>▶ Poisoning (contact with skin or eyes, inhalation or ingestion)</li> <li>▶ Loss of hearing</li> </ul>	    <p>Check the pressure</p>	

Danger	Location	Potential Injuries	Prevention	First Aid
	<ul style="list-style-type: none"> <li>‣ Electric cables and metallic parts</li> <li>‣ Unit enclosure</li> </ul>	<ul style="list-style-type: none"> <li>‣ Electric shock</li> <li>‣ Burns (contact with hot metal/fire)</li> </ul>	 <ul style="list-style-type: none"> <li>‣ Make sure the system has adequate electrical protection</li> <li>‣ Check adequate insulation of all power cables</li> <li>‣ Make sure all metallic parts are earthed</li> </ul>	<p>For severe burns or electric shocks, seek immediate medical help</p>
	<p>Entire unit</p>	<ul style="list-style-type: none"> <li>‣ Burns due to fire</li> <li>‣ Poisoning (inhalation of fumes)</li> </ul>	 <ul style="list-style-type: none"> <li>‣ Make sure the heat pump is installed outdoors and there is sufficient ventilation.</li> <li>‣ Make sure that the heat pump is not installed close to a source of flame.</li> <li>‣ Avoid all possible sources of ignition (flames or sparks) and static discharge of oxidizing material.</li> </ul>	<p><b>In case of burns:</b></p> <ul style="list-style-type: none"> <li>‣ In case of light burns, pour cold water on the wounds and dress the wounds.</li> <li>‣ In case of severe burns, seek medical assistance</li> </ul> <p><b>In case of inhalation:</b></p> <ul style="list-style-type: none"> <li>‣ Move the person away from the source of exposure, keep them warm and let them rest</li> <li>‣ Administer oxygen if necessary</li> <li>‣ Attempt artificial respiration if breathing has stopped or shows signs of stopping</li> <li>‣ If the heart stops, perform external heart massage</li> <li>‣ Seek medical assistance</li> </ul>

# PRODUCT DESCRIPTION

## AURAX ECO

### General Description

The AURAX ECO is a high-efficiency reversible air-to-water heat pump. It is designed to operate efficiently in heating mode even at outdoor temperatures of -15 °C, producing hot water up to 58 °C.

All models are reversible, meaning they can also produce chilled water.

All 2-pipe models are equipped with two hydraulic connections. The activation of an external 3-way valve (optional) allows for priority year-round production of domestic hot water (DHW), hot water for heating in the winter period and chilled water for cooling in the summer period.

The 4-pipe models have 2 additional connections dedicated for domestic hot water system (external 3-way valve is not required).

The units are equipped with scroll-type compressors that efficiently use the refrigerant cycle when the source temperature is low. The compressors are protected by a crankcase heater and a thermal overload protection. They are installed in a separate enclosure, allowing maintenance during operation.

The air-refrigerant heat exchanger is made of copper tubes and aluminium fins, whose design guarantees a low air-side pressure drop, meaning a low rotation speed, and less noise of the fans. The fans are equipped with a safety guard and direct drive axial type and are fixed to the frame by anti-vibration rubber mounts.

The units are equipped with a reverse cycle valve that allows easy defrost in winter. The function is managed automatically by the microprocessor and also allows summer/winter change over.

### Refrigeration circuit

The refrigeration circuit is made using components from leading international companies, according to Directive 2014/68/EU (PED) about the construction of pressure equipment and EN 13134 about brazing processes. The refrigerant gas used is R454B.

The refrigeration circuit includes: a liquid sight glass, a filter dryer, single or double expansion valve according to the appliance power, a 4-way valve, one-way valves, a liquid receiver, Schrader valves for maintenance and control and safety devices (according to PED).

### Controller

All standard units are supplied with a controller. The controller measures system parameters such as water temperature, refrigerant pressure and temperature. It offers frost protection, compressor timing, compressor start sequence (in the case of multiple compressors present), and alarm reset.

The control panel has a display and user interface. The controller is set to handle automatic defrosting (when operating under severe outdoor conditions) and summer/winter switching. The controller is also capable of managing an anti-Legionella thermal shock program and co-sending DHW by enabling specific functions. The controller can be connected to BMS remote control system using the Modbus protocol.

### Control and Protection Devices

All units are supplied with the following control and protection devices:

- ▶ utility water return temperature probe,
- ▶ high pressure switch with automatic reset,
- ▶ low pressure switch with automatic reset,
- ▶ compressor thermal protection,
- ▶ fan thermal protection,
- ▶ pressure transducer,
- ▶ paddle water flow switch,
- ▶ safety valves on the refrigerant circuit.

## Options

### 4-pipe system

Thanks to a dedicated hydraulic circuit, the Aurax heat pump with 4-pipe system produces DHW year-round as a priority, hot water for heating in winter, and chilled water for cooling in summer.

In summer, it can produce chilled water and domestic hot water simultaneously with total heat energy recuperation, significantly reducing energy costs.

The unit is to be combined with a 4-pipe system where 2 pipes are dedicated to the user circuit (heating/cooling) and 2 pipes are dedicated to the domestic hot water (DHW) circuit.

### Single pump kit

This hydraulic kit includes a circulating water pump for heating or cooling. It is suitable for hydraulic circuits with standard pressure drop according to accessory data sheet. In addition, the hydraulic kit is supplied with protective circuit breaker and control contactor (controlled directly by the heat pump controller). For proper operation it is recommended to maintain the velocity of water/glycol under 2 m/s and limit the pressure drop of the system below limit given in the accessory data sheet.

### Centrifugal fan

The option involves replacing the axial fans, provided in the standard version, with high-performance Plug Fan EC centrifugal fans that make it possible to duct air in expulsion. The swivelling plenum provided for each individual fan and included in the option, facilitates the connection to the exhaust duct so as to allow the installation of the heat pump inside a technical room, in any case adequately ventilated.

### Super silence

With the Super silence option, in addition to the compartment where the compressors are located being silenced, each compressor is covered with a bell of a highly soundproofing material.

Also, all fans are coupled with AxiTop diffusers that, while maintaining the same air flow, are able to reduce the unit sound power and energy consumption (by up to 27 % compared to the standard version). The simultaneous action of these two measures results in a reduction of the sound power by 4 to 5 dB(A)

### Refrigerant gas leak detector

Electronic type device with semiconductor sensor. Installed in the compressor compartment. In the presence of refrigerant gas, it sends alarm signal to the microprocessor, which shuts down all equipment in the unit but does not disconnect its power supply.

### Heat exchanger antifreeze resistance

Heating element (flexible resistance band) installed to protect the plate heat exchanger inside the unit in both the standard (2-pipe system) and optional (4-pipe system) versions.

### Condensate tray heating element

Heating element to prevent ice formation inside the condensate tray.

### Electronic soft starter

Electronic device that reduces the inrush current to the same value as the maximum operating current. The option is provided for each type of compressor.

### Refrigerant manometer

Installed on the board of the unit, it enables quick reading of the operating pressures of the refrigerant circuit.

### Compressor shut-off valve

It allows the compressor to be isolated from the refrigerant, facilitating maintenance operations.

### Heat exchanger anti-corrosion treatment

Special treatment with Electrofin E-Coating for installations located near the seaside or in aggressive environments, where the exchanger requires an anti-corrosion treatment.

## Accessories

### Anti-vibration rubber dampers

They reduce the transmission of vibrations produced by the unit. They should be installed on the feet of the unit for optimal performance

### Remote display

Remote display is used for operating and controlling the unit remotely: power on/off, set point selection, summer/winter mode, reading pressures, operating temperatures and alarms. The display allows remote connection up to 50 m.

### Cascade controller

It manages up to 6 units in cascade: on/off, rotation, alarms and circulation water pumps.

### X-web

Enables remote control by user via Modbus.



*For more information regarding the available accessories, please contact your AIC representative.*

## PRODUCT DESCRIPTION

### Heat pump main components

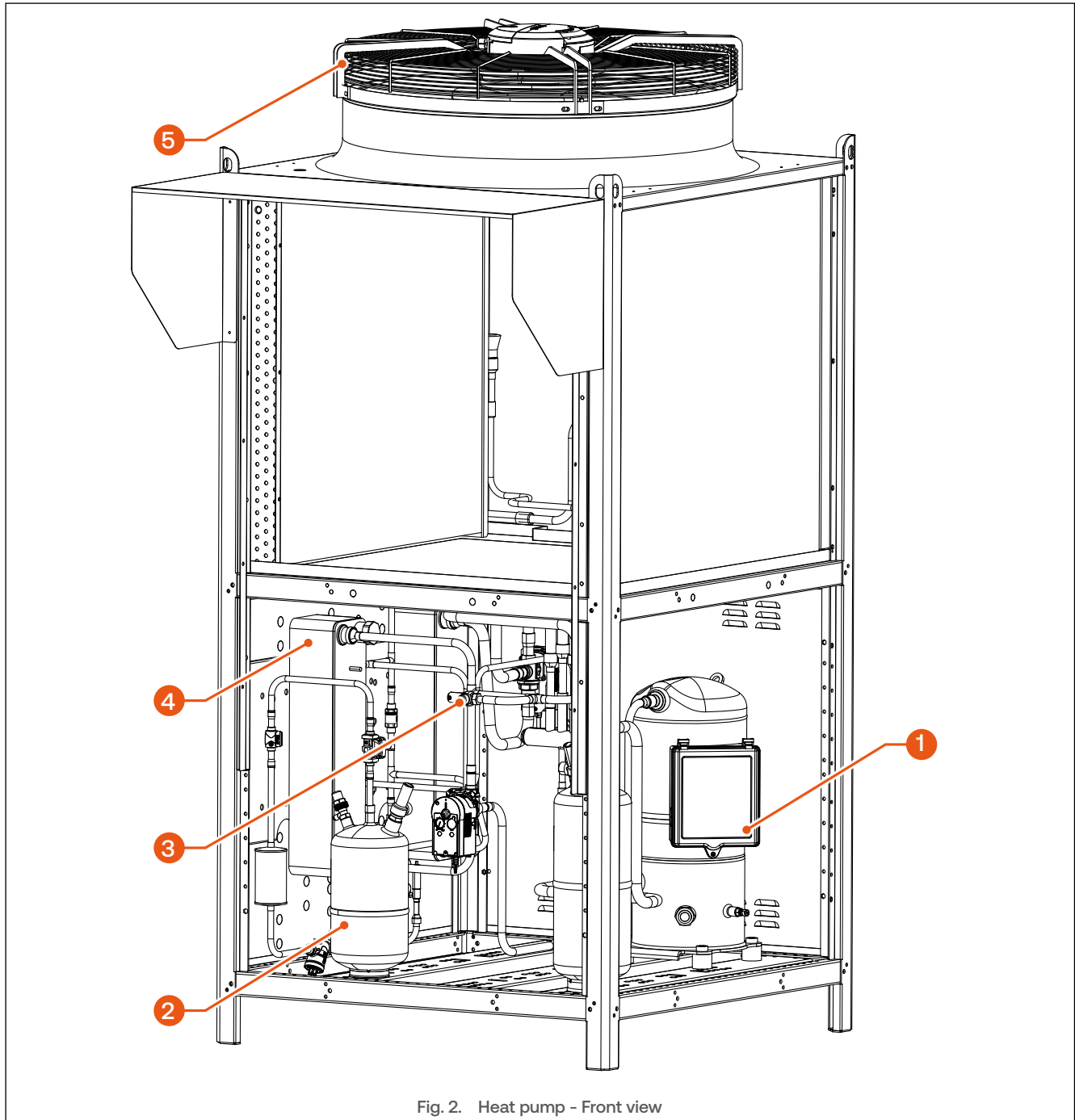

Fig. 2. Heat pump - Front view

• The position and/or aspect of the components inside the heat pump can slightly differ according to the model

#### KEY:

- |                           |                               |
|---------------------------|-------------------------------|
| 1. Compressor             | 6. Expansion valve            |
| 2. Liquid receiver        | 7. Liquid separator           |
| 3. 4-way reversible valve | 8. Finned coil heat exchanger |
| 4. Plate heat exchanger   |                               |
| 5. Fan                    |                               |

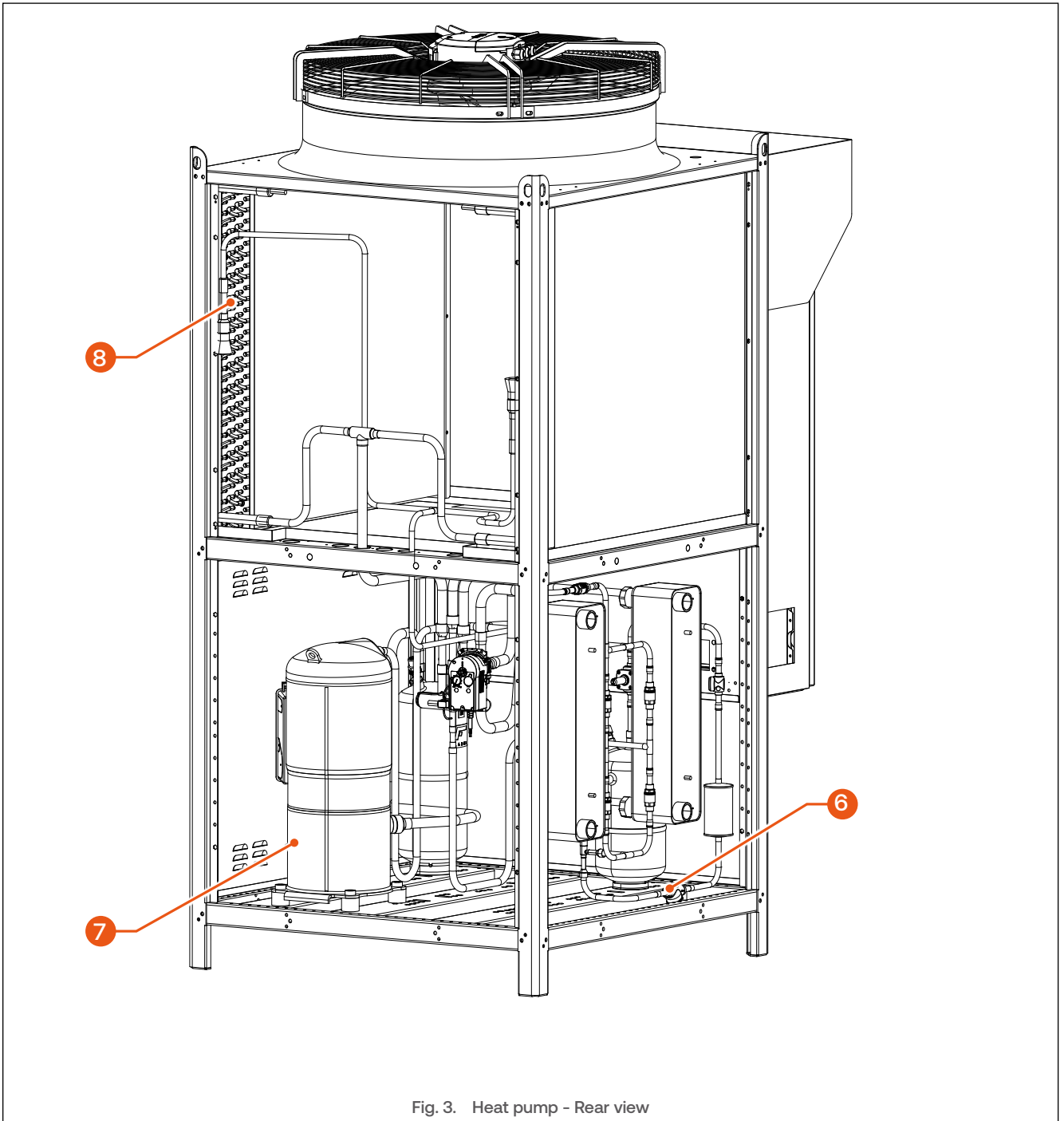

Fig. 3. Heat pump - Rear view

• The position and/or aspect of the components inside the heat pump can slightly differ according to the model

# PRODUCT DESCRIPTION

## Control Panel and Main Functions

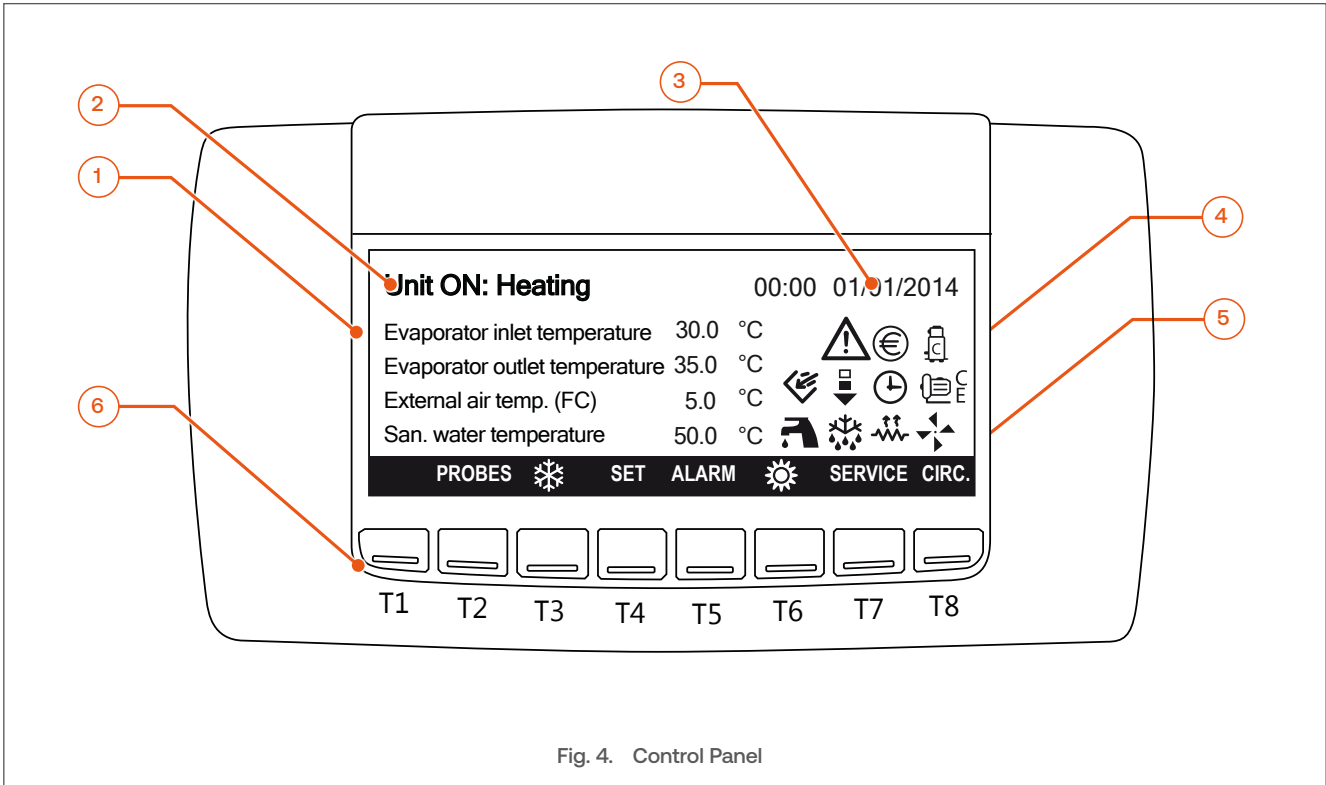













Fig. 4. Control Panel

### KEY



- 1. LCD Display** - The display contains the operating information, parameters, symbols, messages and menus. For a detail of the symbols and menus displayed on the screen, see [page G-17](#)
- 2. Operation status** - Indicates the current operating condition: On or Off, Heating or Cooling, etc.
- 3. Clock** - indicates the current date and time.
- 4. Symbol area** - Zone of the screen where the system icons are displayed, indicating that a function or circuit is activated.
- 5. Horizontal menu bar** - Indicates the available functions that can be activated through the keys underneath. Depending on the activated function, the contents of the menu bar change.
- 6. T1 to T8 function keys** - to activate the functions displayed in the menu bar above.
- 7. Messages and set points area** - Location where the set points and messages are displayed on the screen.  
  
The screen parameters such as brightness and contrast, language, etc. can be adjusted through the Service function and the  icon.  
  
See the opposite page and "[Control panel screen and Language Setup](#)" on [page U-33](#).

## Symbols and Functions on the Control Panel

**Icons in the Symbol area** of the display (some of them will appear only if the function or circuit is enabled):



-  **Compressor.** Indicates that the compressors are in operation.
-  **Water pump.** Indicates that the pump is in operation.
-  **Fans.** Indicates that the fans are in operation.
-  **Domestic Hot Water.** Indicates that the Domestic Hot Water mode is activated.
-  **Alarm.** Indicates that an alarm is active and requires attention.
-  **Economy mode.** Indicates that the unit is operating in economy mode.
-  **Unloading.** Indicates that the unloading function is activated.
-  **Electric Heater.** Indicates that the electric heater is activated.
-  **Timer.** Indicates that the Economy mode or unit is ON/OFF according to the setting of the timer.
-  **Defrost.** Indicates that the defrosting function is active.



**Icons and functions** appearing in the **menu bar** - they are activated by pressing the key located under each of them:

-  **Power** - To turn the unit off
-  **Cooling** - To enable the unit in cooling function.
-  **Heating** - To enable the unit in heating function.
- PROBES** Activate this function to read the value of the installed and configured sensors.
- SET** Activate this function to modify a parameter.
- ALARM** Activate this function to read and reset the alarms.
- SERVICE** Activate this function to access the service menu. See also the service-related icons opposite.
- CIRC** Activate this function to get the information on the circuits (compressors, water pump, sensors, etc.)
- ENTER** Activate this key to validate a value or selection.
- EXIT** Activate this key to go back to the main menu.
- RESET** Activate this key to reset an alarm that is not active.













**RST ALL** Activate this key to reset all the alarms that are not active.

**ENB/DIS** To enable/disable functions (only for Service personnel).

 &  These keys allow to move up and down the list of menu items/ increase or decrease a value.

 &  These keys allow to scroll through the screens.

**Service symbols** appearing on the **Display**:

-  **Service menu** (Service only). To access the service menu and set the parameters.
-  **Time and date.** To carry out time and date setting and read time band settings.
-  **Compressors.** To display the status of the compressors (working hours, number of activation).
-  **Pumps.** To display the status of the water pumps (working hours).
- CIR** **Circuits.** To display the status of the circuits.
-  **Alarms.** To access the current alarms
-  **Alarm log.** To access the list of alarms (up to `99 are stored).
-  **Defrost** (if available). To read the status of defrost for each circuit.
-  **Electrical Heater.** To read the status of the electrical heaters.
-  **Input/output.** To read the probe status, analog/digital input and output.
-  **Screw compressor** (if available). To display the discharge temperature and liquid injection set point.
-  **Auxiliary output.** To read information about auxiliary output.
-  **Domestic Hot Water.** To read information about the DHW circuit control.
- HOTKEY** **Upload/Download** (service only)
-  **Control panel setup.** To access contrast and backlight, language selection, system information, etc.

\* *Some functions visible on the control panel may not be available, as they depend on the heat pump model.*

# TECHNICAL SPECIFICATIONS

## Dimensions and weight

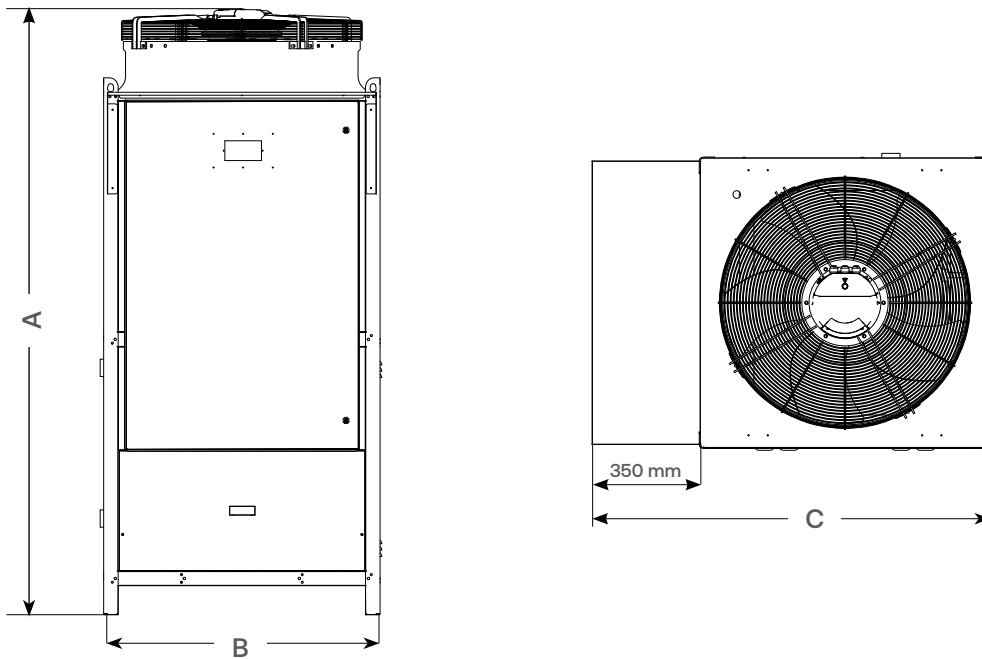

### Dimensions

#### AURAX ECO

			AE 25.1	AE 28.1	AE 30.1	AE 35.1	AE 38.1	AE 45.1	AE 55.1
A	height (without anti-vibration feet)	mm	2067	2067	2067	2067	2067	2067	2067
B	width	mm	952	952	952	952	952	952	952
C	depth	mm	1302	1302	1302	1302	1302	1302	1302
	weight	kg	450	450	450	450	453	455	460

### Connections

#### AURAX ECO

			AE 25.1	AE 28.1	AE 30.1	AE 35.1	AE 38.1	AE 45.1	AE 55.1
flow/return threaded connections [F]	Ø		1¼"	1¼"	1¼"	1¼"	1¼"	2"	2"
water inlet connection	Ø		1¼"	1¼"	1¼"	1¼"	1¼"	2"	2"
water outlet connection	Ø		1¼"	1¼"	1¼"	1¼"	1¼"	2"	2"
water pipe diameter	mm		42,4	42,4	42,4	42,4	42,4	60,3	60,3

Clearances

Wall layout - 1 wall

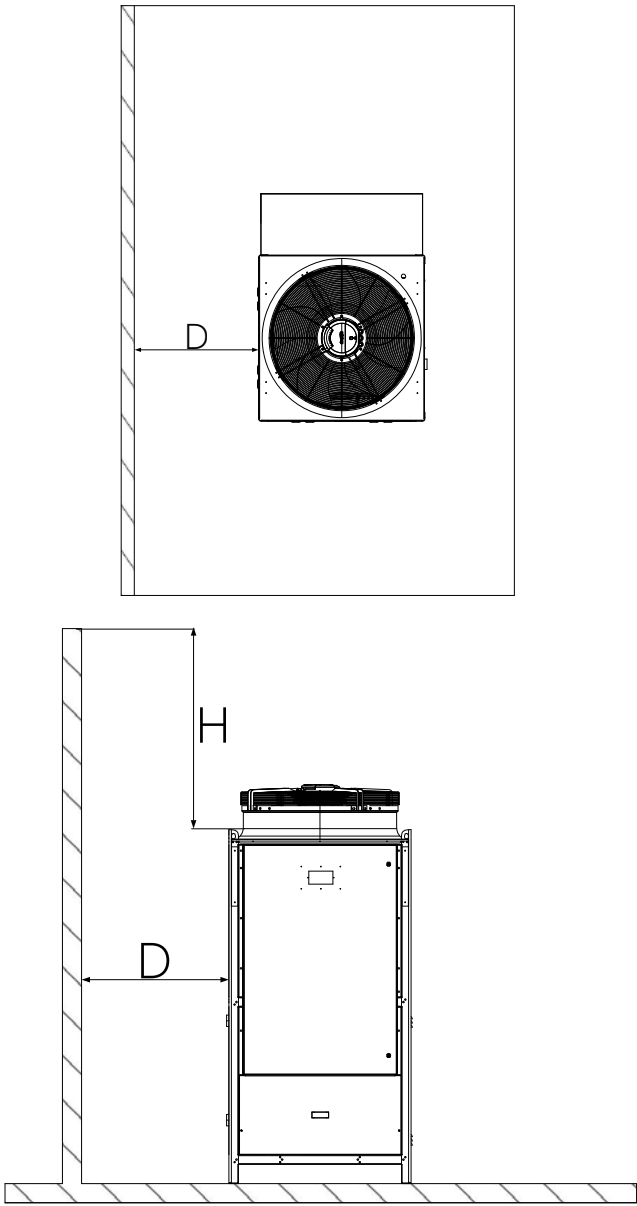

Number of Heat Pumps	H ≤ 0 [m]	0 ≤ H ≤ 1 [m]	1 ≤ H ≤ 3 [m]	3 ≤ H [m]
	D			
1	1,2	1,2	1,2	1,2
2	1,2	1,2	1,2	1,2
3	1,2	1,2	1,2	1,35
4	1,2	1,2	1,35	1,5
5 ≥	1,2	1,35	1,5	1,65

# TECHNICAL SPECIFICATIONS

## Wall layout - 2 walls (L shape)

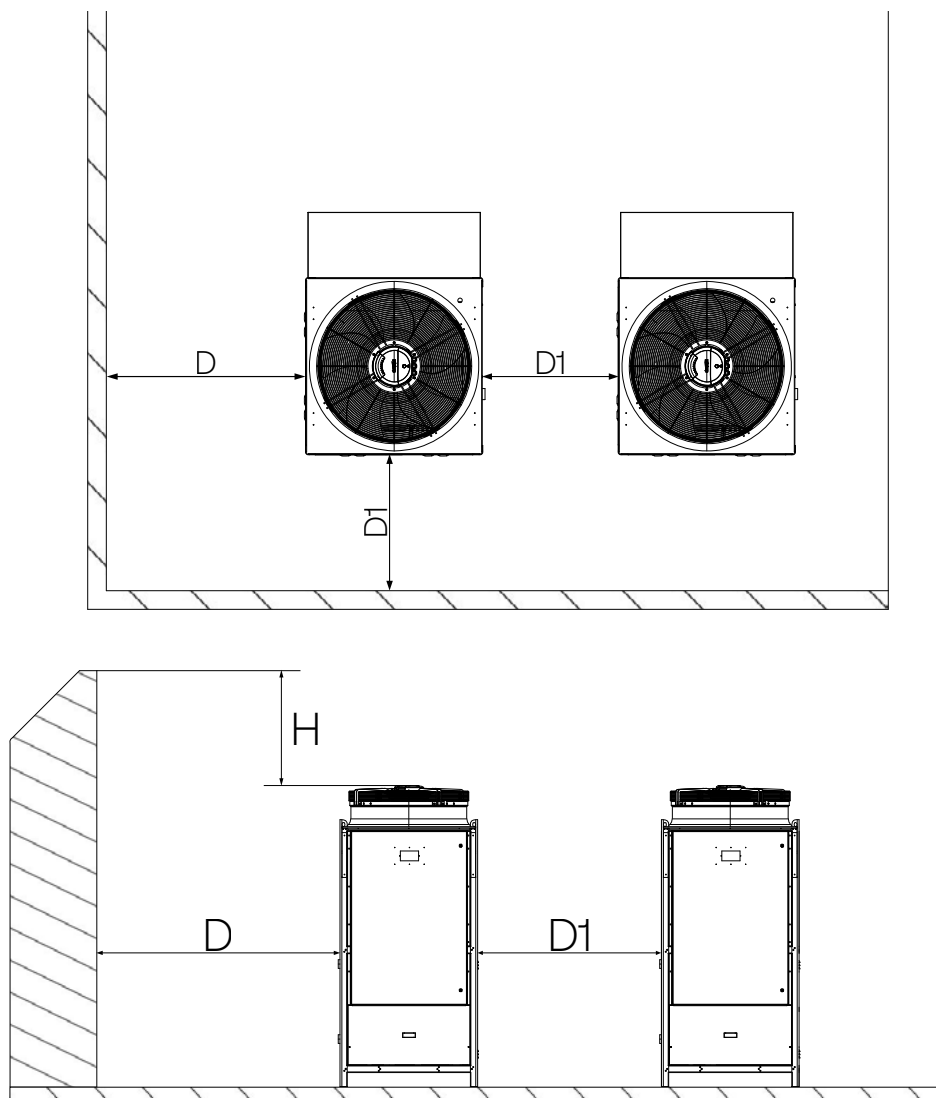

Number of Heat Pumps	D1* [m]	H ≤ 0 [m]	0 ≤ H ≤ 1 [m]	1 ≤ H ≤ 3 [m]	3 ≤ H [m]
		D [m]			
1	1,2	1,2	1,2	1,2	1,2
2	1,2	1,2	1,2	1,35	1,5
3	1,2	1,35	1,35	1,5	1,65
4	1,2	1,5	1,5	1,65	1,8
5 ≥	1,2	1,65	1,65	1,8	1,95

\* Minimum distance for service

Wall layout - 3 and 4 walls.

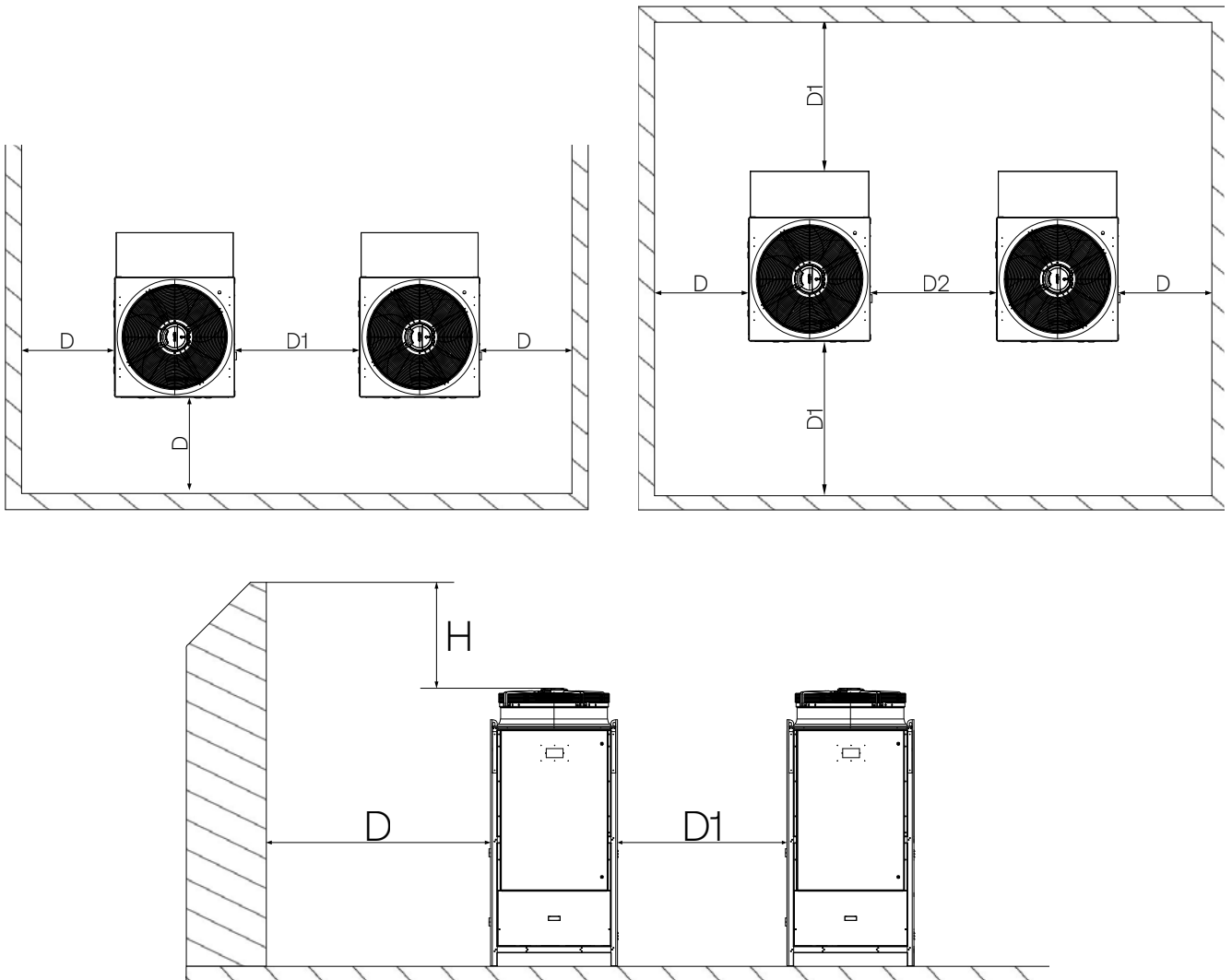

Number of Heat Pumps	D1* [m]	H≤0 [m]	0≤H≤1 [m]	1≤H≤3 [m]	3≤H [m]
		D[m]			
1	1,2	1,2	1,2	1,2	1,2
2	1,2	1,35	1,5	1,65	1,8
3	1,2	1,5	1,65	1,8	1,95
4	1,2	1,65	1,8	1,95	2,1
5≥	1,2	1,8	1,95	2,1	2,25

\* Minimum distance for service

# TECHNICAL SPECIFICATIONS

## Primary Circuit Performance Data

### AURAX ECO

			AE 25.1	AE 28.1	AE 30.1	AE 35.1	AE 38.1	AE 45.1	AE 55.1
heating*(A7/6, W30/35)	capacity	kW	24,7	28,3	30,0	34,9	37,9	44,7	55,5
	power input	kW	5,7	6,5	6,8	8,0	9,2	10,4	13,3
	COP		4,34	4,35	4,43	4,36	4,10	4,28	4,16
heating*(A7/6, W47/55)	capacity	kW	21,6	24,9	28,4	31,4	35,1	41,4	54,1
	power input	kW	8,4	9,5	9,9	11,7	13,2	15,2	19,6
	COP		2,57	2,62	2,62	2,70	2,67	2,73	2,76
cooling* (A35, W23/18)	capacity	kW	18,9	22,3	25,6	27,6	32,1	36,3	49,4
	power input	kW	7,1	7,8	8,2	10,0	11,4	13,1	16,2
	EER		2,67	2,84	3,13	2,76	2,81	2,78	3,04

\* according to EN 14511

## ErP Data

### AURAX ECO

		AE 25.1	AE 28.1	AE 30.1	AE 35.1	AE 38.1	AE 45.1	AE 55.1
air to water heat pump	Y/N	Y	Y	Y	Y	Y	Y	Y
low-temperature heat pump	Y/N	N	N	N	N	N	N	N
equipped with a supplementary heater	Y/N	N	N	N	N	N	N	N
heat pump combination heater	Y/N	N	N	N	N	N	N	N
temperature application	°C	35 °C/55 °C	35 °C/55 °C	35 °C/55 °C	35 °C/55 °C	35 °C/55 °C	35 °C/55 °C	35 °C/55 °C
climate conditions		average	average	average	average	average	average	average
SCOP* 35 °C / 55 °C		3,78 / 2,86	3,75 / 2,87	3,79 / 3,22	3,76 / 3,14	3,53 / 3,08	3,63 / 2,89	3,52 / 2,91
annual energy consumption QHE	GJ	48,6	56,1	58,9	69,0	79,9	91,6	117,3
seasonal space heating energy efficiency $\eta_s$	%	151/114	150/115	152/129	150/126	141/123	145/116	141/116
seasonal space heating energy efficiency class		A++/A+	A++/A+	A++/A++	A++/A++	A+/A+	A+/A+	A+/A+
range of energy efficiency classes		A+++→D	A+++→D	A+++→D	A+++→D	A+++→D	A+++→D	A+++→D
SEER (7 °C)		4,14	4,32	4,41	4,12	4,21	4,25	4,23
SEPR		2,63	2,54	3,73	3,65	3,63	3,65	3,32
sound power level, outdoors LWA**	dB(A)	74	74	74	75	76	78	75
sound pressure level LpA @ 10m**	dB(A)	46	46	46	47	48	50	47

\*according to EN 14511

\*\*according to ISO EN 3744

## Refrigerant

	AURAX ECO							
	AE 25.3	AE 28.1	AE 30.1	AE 35.1	AE 38.1	AE 45.1	AE 55.1	
number of circuits	1	1	1	1	1	1	1	
number of compressors	1	1	1	1	1	1	2	
compressor type	scroll							
refrigerant gas type	R454B							
refrigerant charge	kg	7,1	10,1	10,1	10,1	10,94	12,0	12,44
global warming potential (GWP)		466	466	466	466	466	466	466
equivalent CO <sub>2</sub> charge	t	3,3	4,7	4,7	4,7	5,1	5,6	5,8
number of fans		1	1	1	1	1	1	1
diameter of fan	mm	800	800	800	800	800	800	800
max. air flow rate	m <sup>3</sup> /h	10000	10000	10000	18000	18000	18000	18000
air/refrigerant exchanger		1	1	1	1	1	1	1
water/refrigerant exchanger		1	1	1	1	1	1	1



The refrigerant data may change without notice. Always refer to the silver label placed on the unit.

## Electrical Data

		AURAX ECO							
		AE 25.1	AE 28.1	AE 30.1	AE 35.1	AE 38.1	AE 45.1	AE 55.1	
supply voltage/phase/freq.	V/ph/Hz	400/3+PE+N/50	400/3+PE+N/50	400/3+PE+N/50	400/3+PE+N/50	400/3+PE+N/50	400/3+PE+N/50	400/3+PE+N/50	
max. power input / rated current	kW/A	10,9/13	11,6/15	12,7/15	14,4/18	15,5/21	17,7/24	24,9/29	
maximum absorbed current	No built-in water pump	25	28	25	28	29	34	45	
	2-pipe unit 1 built-in water pump	A 27	30	26	29	30	35	46	
	4-pipe unit 2 built-in water pumps	28	31	27	30	32	36	47	
max. starting current	No built-in water pump	101	145	126	141	148	175	214	
	2-pipe unit 1 built-in water pump	A 103	147	128	143	150	177	216	
	4-pipe unit 2 built-in water pumps	104	148	129	144	151	178	217	

# TECHNICAL SPECIFICATIONS

## Primary Circuit Hydraulic Data

		AURAX ECO							
		AE 25.1	AE 28.1	AE 30.1	AE 35.1	AE 38.1	AE 45.1	AE 55.1	
heating	min water content	l	327	375	397	462	502	591	637
	pressure drop at $\Delta T = 5k$	kPa	18	22	25	32	36	25	25
	min. operating pressure	MPa	0,2	0,2	0,2	0,2	0,2	0,2	0,2
	max. operating pressure	MPa	0,6	0,6	0,6	0,6	0,6	0,6	0,6
	min. operating temperature	°C	5	5	5	5	5	5	5
	max. operating temperature	°C	58	58	58	58	58	58	58
	nom. water flow rate at $\Delta T = 5k$	m <sup>3</sup> /h	4,3	4,9	5,2	6	6,5	7,7	9,5

\* according to EN 14511

## Options

### Single pump kit

		AURAX ECO						
		AE 25.1	AE 28.1	AE 30.1	AE 35.1	AE 38.1	AE 45.1	AE 55.1
supply voltage/ phase/freq.	V/ph/Hz	230/ 1+N+Pe/50	230/ 1+N+Pe/50	230/ 1+N+Pe/50	230/ 1+N+Pe/50	230/ 1+N+Pe/50	230/ 1+N+Pe/50	400/ 1+N+Pe/50
nom. flow rate at $\Delta T=5K$	m <sup>3</sup> /h	4,3	4,9	5,2	6	6,5	7,7	9,5
primary circuit pump head	mH <sub>2</sub> O	11	16	16	15,5	15	14,3	15,3
primary circuit pump available head	mH <sub>2</sub> O	8	13,8	13,5	12	11	11,3	12,3
water pump electricity consumption	kW	0,28	0,42	0,44	0,52	0,52	0,62	0,61
water pump absorbed current	A	1,2	1,8	1,9	2,3	2,3	2,7	1,0

### 4-pipe system

		AURAX ECO						
		AE 25.1	AE 28.1	AE 30.1	AE 35.1	AE 38.1	AE 45.1	AE 55.1
<b>Connections</b>	Ø							
flow/return threaded [F]	in	1¼	1¼	1¼	1¼	1¼	2	2
water inlet	in	1¼	1¼	1¼	1¼	1¼	2	2
water outlet	in	1¼	1¼	1¼	1¼	1¼	2	2
DHW pipe diameter	mm	42,4	42,4	42,4	42,4	42,4	60,3	60,3

Performance data\*

AURAX ECO

			AE 25.1	AE 28.1	AE 30.1	AE 35.1	AE 38.1	AE 45.1	AE 55.1
heat pump mode (A 7/6, DHW 50-55)	capacity	kW	21,6	24,9	28,4	31,4	35,1	41,4	54,1
	rated power input	kW	8,4	9,5	9,9	11,7	13,2	15,2	19,6
	COP		2,57	2,62	2,87	2,70	2,67	2,73	2,76
chiller mode (A 12/7, DHW 55-58)	capacity	kW	25,3	29,8	32,4	37,6	40,8	48,1	63,1
	rated power input	kW	7,7	8,8	9,0	10,3	11,2	13,5	17,9
	COP		3,28	3,40	3,16	3,7	3,6	3,6	3,5
	TER		5,4	5,6	6,0	6,0	5,9	5,8	5,8

\*circuit with technical water for DHW water production

Hydraulic data

pressure drop at $\Delta T = 5k$	kPa	28	29	32	33	34	34	31
nom. water flow rate at $\Delta T = 5k$	m <sup>3</sup> /h	4,4	5,1	5,6	6,5	7	8,3	10,9
max. DHW temperature	°C	58	58	58	58	58	58	58

Sound Data for Super Silence Option

AURAX ECO

			AE 25.1	AE 28.1	AE 30.1	AE 35.1	AE 38.1	AE 45.1	AE 55.1
sound pressure level LpA @ 10m	dB (A)	42	42	42	43	44	46	43	
sound power level, outdoors LWA	dB (A)	70	70	70	71	72	74	71	

# TECHNICAL SPECIFICATIONS

## Limits of Operation

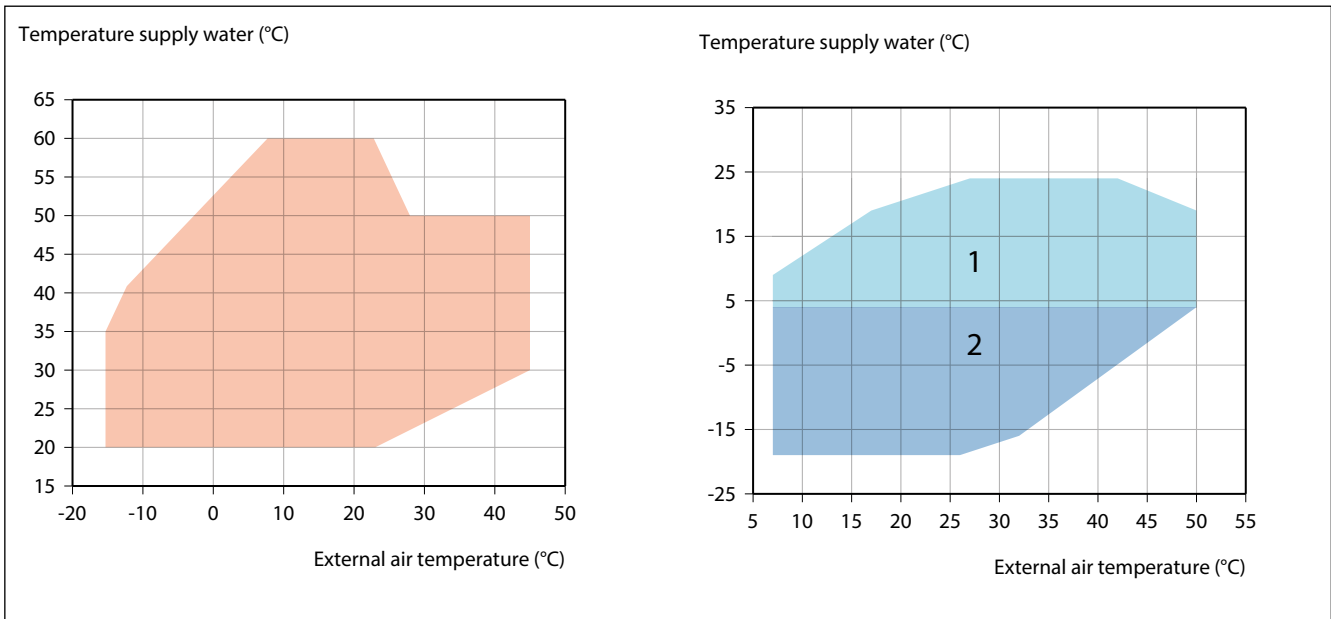

**Legend:**

- 1. Glycol - free
- 2. With ethyl glycol

### Water flow rate utility exchanger

The nominal water flow rate refers to a temperature difference between the inlet and outlet of the utility heat exchanger of  $\Delta t = 5\text{ °C}$ .

The maximum permissible flow rate is that with a thermal jump of  $\Delta t = 3\text{ °C}$ . Lower thermal jump values may result in too high a pressure drop. The minimum permissible flow rate is that with a thermal jump of  $\Delta t = 8\text{ °C}$ .

Insufficient water flow rates can cause abnormal temperatures in the refrigeration circuit with the tripping of safety devices and unit shutdown.

### Utility hot water temperature (winter operation)

Once the system has come up to speed, the temperature at the inlet of the utility and/or DHW exchanger should not fall below  $30\text{ °C}$ . Lower values may cause compressor malfunctions with the possibility of breakdown. The minimum inlet water of the utility heat exchanger during the heating start-up is  $5\text{ °C}$ . The maximum water outlet temperature of the utility exchanger must not exceed  $58\text{ °C}$ . Otherwise, the action of the safety devices will stop the unit.

### Chilled water temperature

The minimum permissible temperature at the outlet of the utility exchanger is  $5\text{ °C}$ : for lower temperatures the unit needs modifications. In this case contact our technical department.

The maximum water temperature produced is  $24\text{ °C}$ .

### Outdoor temperature

The units operate in heating mode with an outdoor temperature between  $-15\text{ °C}$  and  $45\text{ °C}$ .

They operate in chiller (cooling) mode with an outdoor temperature between  $7\text{ °C}$  and  $50\text{ °C}$ .

## Correction Factors

## Corrections for Operation with Glycol

Glycol percentage	Freezing point (°C)	Capacity Correction Factor (CCF)	Input Power Correction Factor (IPCF)	Water Flow Correction Factor (WFCF)	Pressure Drop Correction Factor (PDCF)
10%	-3,6	0,986	1	1,02	1,06
20%	-8,7	0,980	0,995	1,054	1,114
30%	-15,3	0,973	0,990	1,092	1,190
40%	-23,5	0,966	0,985	1,140	1,244
50%	-35,5	0,960	0,975	1,200	1,310



The water flow rate and pressure drop correction factors must be applied directly to the values given for operation without glycol:

- ▷ The water flow rate correction factor is calculated to maintain the same temperature difference as without glycol.
- ▷ The pressure drop correction factor takes into account the different flow rate obtained from the application of the flow rate correction factor.

 Corrections for Different  $\Delta T$  and Different Fouling Factors

Water temperature difference (°C)	3	5	8
Cooling Capacity Correction Factor (CCCP)	0,99	1,00	1,02
Input Power Correction Factor (IPCF)	0,99	1,00	1,01
Fouling factor	0,00005	0,0001	0,0002
Cooling Capacity Correction Factor (CCCP)	1,00	0,98	0,96
Input Power Correction Factor (IPCF)	1,00	0,99	0,99

# TECHNICAL SPECIFICATIONS

## Water Quality Guidelines for Air-to-Water Heat Pumps



To ensure optimal performance and longevity of an air-to-water heat pump system, it is crucial to follow these water quality recommendations.

### Recommended Water Quality Parameters

pH.....	7-9,5	Oxygen O <sub>2</sub> .....	5-10 mg/l
Electrical conductivity.....	100-700 µS/cm	Nitrates.....	< 5 mg/l
Sulphates SO <sub>4</sub> .....	< 100 mg/l	Ammonia.....	None
Bicarbonate HCO <sub>3</sub> .....	< 200 mg/l	Hydrogen sulphide H <sub>2</sub> S.....	None
Chloride Cl.....	< 50 mg/l	Chlorite.....	None
Phosphate PO <sub>4</sub> .....	< 2 mg/l	Free chlorine.....	< 0,2 mg/l
Carbon dioxide CO <sub>2</sub> .....	< 5 mg/l		

### Recommended measures to Improve Water Quality:

- ▶ **Flushing the system:**  
Before starting the system for the first time, thoroughly flush it to remove any debris and reduce the risk of sludge and scale buildup.
- ▶ **Mechanical and magnetic filters:**  
Install mechanical and magnetic filters to capture particulates and magnetite, protecting the heat exchangers from contamination.
- ▶ **Automatic air vents:**  
Use automatic air vents to remove air from the system, minimizing oxygen content and reducing the risk of corrosion.
- ▶ **Corrosion inhibitors:**  
Apply chemical inhibitors to prevent corrosion, especially in systems with metallic components.
- ▶ **Regular maintenance:**  
Perform routine checks on water quality and filter conditions. Regularly clean or replace filters as needed to maintain system performance.

## Safety Instructions for the User



- ▶ This appliance is not intended for use by persons (including children) with reduced physical, sensory or mental capabilities, or lack of experience and knowledge, unless they have been given supervision or instruction concerning use of the appliance by a person responsible for their safety. Children should be supervised to ensure that they do not play with the appliance.
- ▶ Do not smoke, using open flames or create sparks in the vicinity of the appliance.
- ▶ Electrical devices with ignition sources and mobile devices with batteries must be strictly avoided within the safety area.
- ▶ Do not store any flammable, corrosive or explosive products near the appliance.
- ▶ Do not modify or deactivate any component, nor any safety device in the system.
- ▶ Do not operate the appliance when the casing is open.



- ▶ Do not modify any part of the electrical system or access internal components.
- ▶ Do not touch the appliance with any wet body parts when the appliance is supplied with electrical power.



- ▶ Do not modify or block the condensate outlet(s).
- ▶ Do not open any sealed part or component. Failure to comply with this instruction can result in damages and/or injuries.
- ▶ Make sure the appliance and the heating system are prevented from freezing.
- ▶ In case of water leakage, disconnect the appliance from the power supply, turn off the water supply and call a qualified professional.
- ▶ In case of abnormal noises in the system or the appliance, please notify a qualified professional.
- ▶ Any setting of the appliance by the end-user using the installer-specific functions, that would cause the appliance to malfunction, could result in damages to the equipment. Only the end-user settings described in this manual are available to the end-user.

## Disposal of the Product at the End of Service Life



- ▶ *At the end of service life, the product should not be disposed of as solid urban waste, but should be handed over to a differentiated waste collection centre.*
- ▶ *Pay special attention not to discharge the compressor oil onto the ground or into sewers, waterways, groundwater or seawater.*
- ▶ *If the product contain the fluorinated greenhouse gases, they shall be recycled, reclaimed or destroyed according to the applicable local regulations and by qualified professionals*



*When cleaning the appliance cabinet panels, do not use solvents or aggressive/abrasive cleaning agents. Wipe the surfaces using a soft clean cloth, water and soap.*

# INSTRUCTIONS FOR THE USER

## Operating the Controller - End User Level



For the meaning of the icons and functions displayed on the screen, refer to **"Symbols and Functions on the Control Panel"** on page G-17.

### Turning On and Off

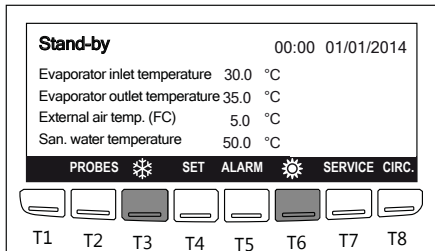

**Depress:**

T6 (☀️) to turn on in Heating mode

T3 (❄️) to turn on in Cooling mode

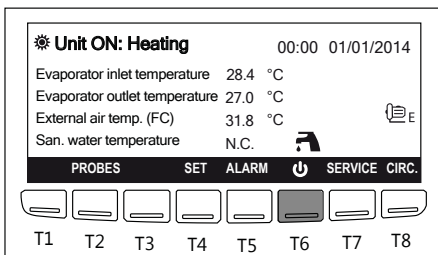

**Depress:**

T6 (⏻) to turn off in Heating mode

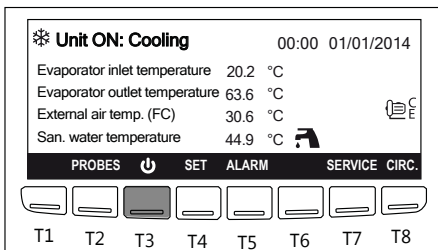

T3 (⏻) to turn off in Cooling mode

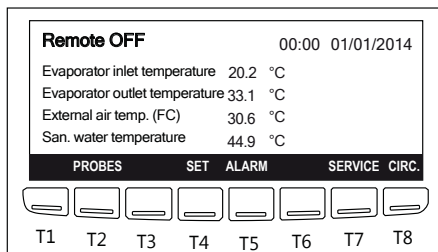

Through the **remote control**, the unit can be turned on and off. If installed, it has priority over manual activation/deactivation.



*In this manual, screens displaying the heating functions are shown as an examples. Depending on the active and of the sensors and components installed in the system, the contents of the screens may differ. The principle of operation and navigation through the screens is however identical.*

## Definition of Set points - SET Function

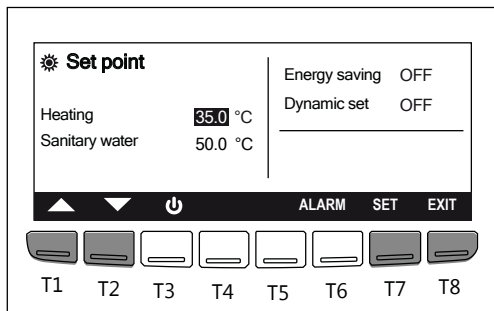
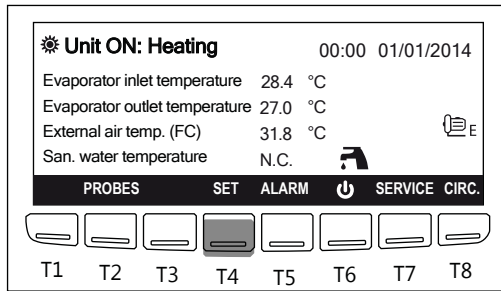

**Depress:**

T4 (SET) to access **Set point** definition screen

**Depress:**

T1 (▲) / T2 (▼) to navigate through the set points.

T7 (SET) to select the value (starts blinking).

T1 (▲) / T2 (▼) to increase/decrease the value.

T7 (SET) to confirm the value.

T8 (EXIT) to exit the screen and return to the home screen

Refer to "**Set points**" on page I-62 for the temperature ranges and default values.

## Resetting an Alarm - ALARM Function

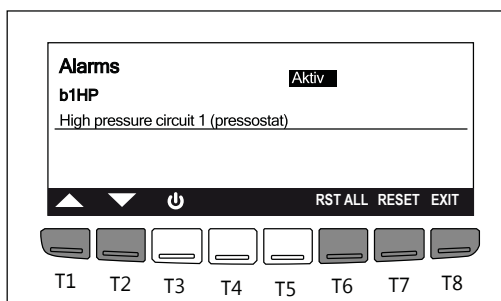
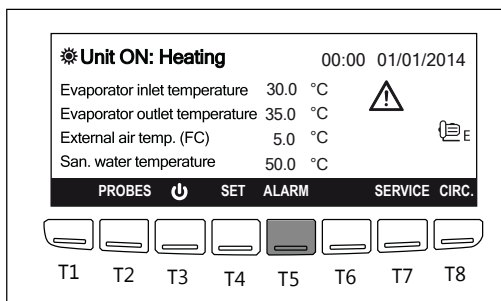

If  is blinking on the screen, an alarm has occurred

**Depress:**

T5 (ALARM) to display the alarm status :

- ▶ **Active** : cannot be reset because it is still active
- ▶ **Password** : no access for the end-user. Please contact your installer/AIC representative
- ▶ **Reset** : alarm is not active and can be removed as follows :

T1 (▲)/T2 (▼) to select the alarm to be deleted

T7 (RESET) to delete one alarm at a time

T6 (RST ALL) to delete all the resettable alarms

T8 (EXIT) to exit the screen and return to the home screen



*If an alarm buzzer is sounding, it can be stopped by pressing and releasing any of the keys.*

# INSTRUCTIONS FOR THE USER

## Setting the Time and Date

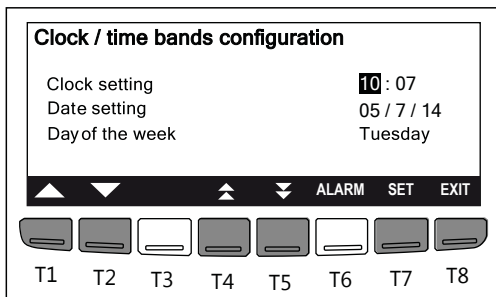
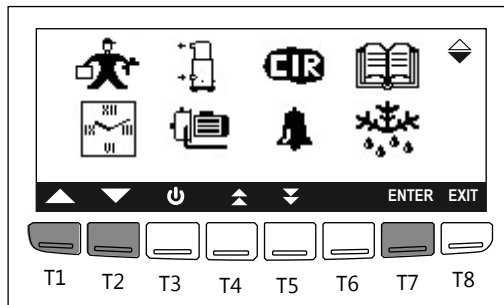
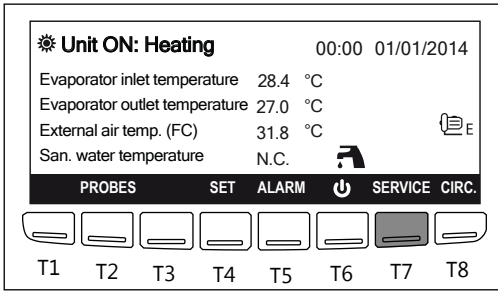

### Depress:

T7 (SERVICE) to access the **Service** screen

### Depress:

T1 (▲) / T2 (▼) to select the  icon.

T7 (ENTER) to confirm and access the **Date and Time** screen

 *When an icon is selected, it is displayed on a black background.*

### Depress:

T1 (▲) / T2 (▼) to scroll through the lines.

T7 (SET) to select the value. It starts blinking.

T1 (▲) / T2 (▼) to increase/decrease the value.

T7 (SET) to confirm the value.

T4 (▲) / T5 (▼) to read the info about the Energy saving, ON/OFF scheduling and time bands on other screens (cannot be modified by the end user).

T8 (EXIT) to exit the menu

## Control panel screen and Language Setup

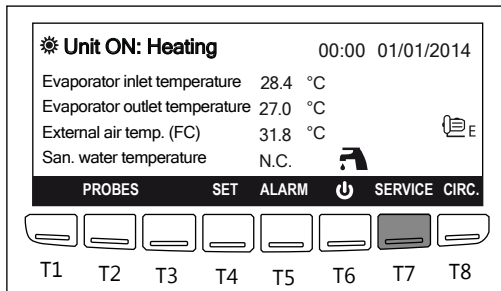

**Depress:**

T7 (SERVICE) to access the Service screen

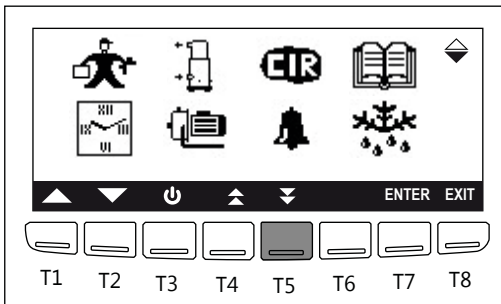

**Depress:**

T5 (▼) to access the second screen of icons

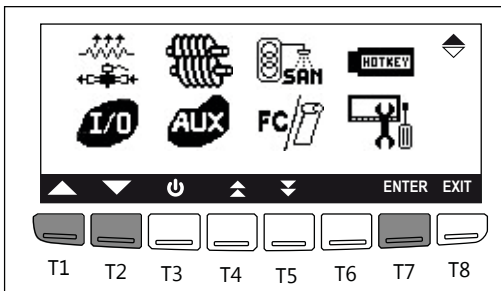

**Depress:**

T1 (▲) / T2 (▼) to select the  icon.

T7 (ENTER) to confirm and access the Control panel screen

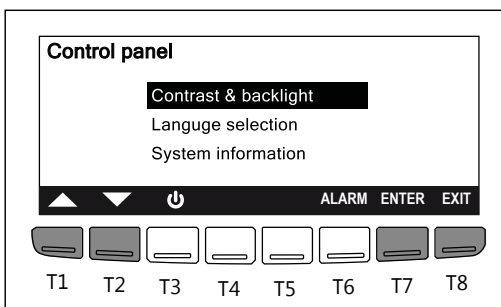

**Depress:**

T1 (▲) / T2 (▼) to scroll through the lines.

T7 (ENTER) to select the line and perform the required adjustments :

- ▶ Contrast and backlight
- ▶ Language selection

or read information:

- ▶ System information

T8 (EXIT) to exit the menu and go back to the home screen.

## Safety Instructions for the Installation



- ▶ All connections must be carried out in accordance with current standards and regulations in force.
- ▶ Make sure to install all required external components to ensure the correct operation of the system.
- ▶ Choose an installation site in accordance with standards EN 378-1 and EN 378-3 and take into consideration risks caused by accidental refrigerant leakage.
- ▶ Do not install and use the unit in environments:
  - ▶ very dusty or with a potentially explosive atmosphere;
  - ▶ where vibrations are present;
  - ▶ presenting electromagnetic fields;
  - ▶ with aggressive atmospheres
- ▶ Do not install the appliance in a location where chemical vapours or dust are present in the ambient air.
- ▶ The use of tools that generate sparks must be strictly avoided within the safety area.
- ▶ For systems using flammable refrigerant, there shall be no refrigerant leaks that will flow or stagnate.
- ▶ Make a complete check of the unit for possible refrigerant leakages due to bad transport conditions.
- ▶ Failure to comply with this requirement may result in a fire or explosion hazard in areas within the unit containing components and devices which may be a source of ignition.



- ▶ The unit is designed for outdoor installation.
- ▶ Do not install the unit in the vicinity of trees or under an overhang.
- ▶ Comply with the clearance dimensions provided in this manual.
- ▶ It is essential to ensure adequate air volume to the source fan. Avoid recirculation of discharged air; failure to observe this point will result in poor performance or activation of safety controls
- ▶ In defrost mode, the heat exchanger will produce condensates, which can create a thick layer of ice if the ambient temperature is below 0 °C. It is therefore recommended to raise the unit by a minimum height of 350 mm to prevent damage to the heat exchanger due to ice formation.
- ▶ Install the unit in such a way as to prevent a slipping hazard to the user or third parties due to the presence of ice around the heat pump.
- ▶ Make sure to protect the unit and the circuits against freezing.
- ▶ The unit must be installed to ensure easy access at all times.
- ▶ Use an appropriate means of handling, suitable to the unit size and weight.
- ▶ Install all pipes and ducts without stress to prevent any leaks from occurring.



- ▶ When the unit is connected to the electrical network, it must be earthed.
- ▶ Make sure that a fuse or circuit breaker of the recommended rating is installed outside the unit, so as to be able to shut the power down.
- ▶ Do not touch the unit with any wet body parts when it is supplied with electrical power.
- ▶ Before performing any operation on the electrical circuit, isolate the electrical supply of the appliance through the external power-cutting device (fuse, circuit breaker, etc.).

### Handling the Unit



▶ This unit is very heavy and requires adequate means of handling and transport. Make sure to comply with applicable local standards and regulations on product handling.

- ▶ Units can be lifted with a forklift or, alternatively, belts, making sure not to damage the side panels or covers.
- ▶ During the handling, keep the unit vertically at all time to avoid damage to the internal components.
- ▶ Also avoid sudden movements in order to protect the refrigerant circuit and other components.
- ▶ Failure to comply with these recommendations can result in damage to the unit or injuries to the personnel.

Safety requirements :



Using an appropriate lifting means, move the unit in its packaging close to the installation location.



▶ The units transmit a low level of vibration to the ground; however, it is advisable to interpose anti-vibration mounts between the base frame and the ground plane.

- ▶ It is very important to avoid recirculation phenomena between air inlet and air outlet, otherwise the performance of the unit will be degraded or even normal operation will be interrupted. In this regard, it is necessary to ensure the minimum service spaces, refer to "Location of the unit" on page I-36.

### Unpacking the Unit

Safety requirements :



The unit is packaged with different materials such as wood, cardboard, nylon, etc.

1. Carefully remove the packaging and protections.
2. Discard packaging according to applicable local regulations.



The maximum ambient storage/transport temperature is +45 °C, the minimum is 2 °C.

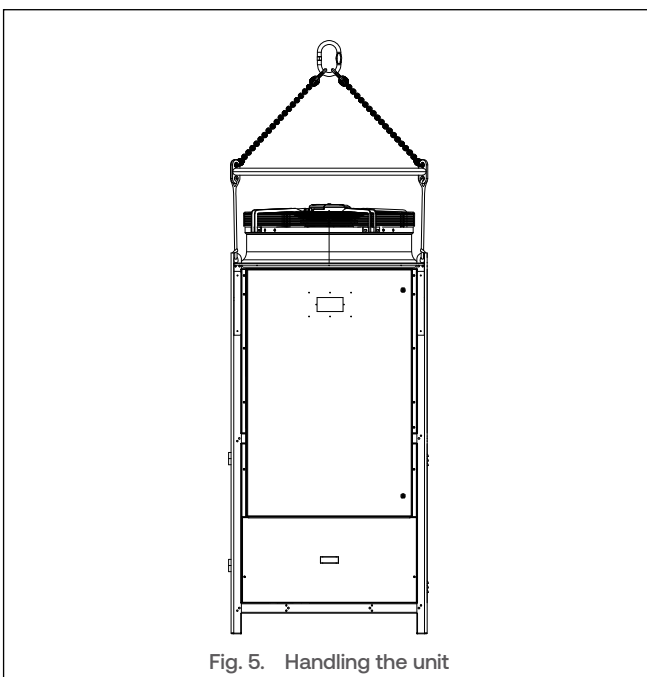

Fig. 5. Handling the unit

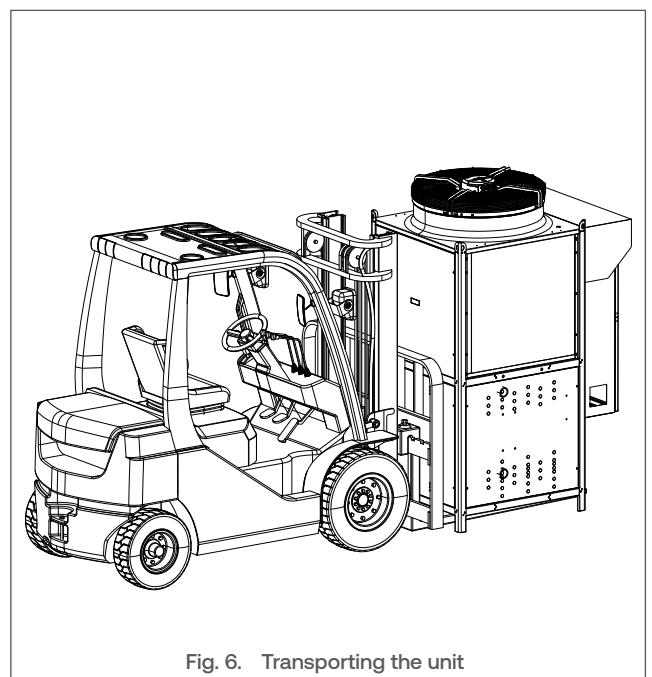

Fig. 6. Transporting the unit

# PRODUCT INSTALLATION

## Installing and Preparing the Unit

Safety requirements :  

Caution :  Heat exchanger fins

- ▶ Make sure to comply with the recommended clearances for the unit installation, refer to "Location of the unit" on page I-36.
- ▶ Make sure to comply with all the safety instructions for the installation, as defined on page I-34.
- ▶ All units are equipped with a condensate tray, which is located below the exchanger (finned coil), collects the condensate water produced by the unit in heating and domestic hot water modes.
- ▶ Provide a heating cable in the discharge pipe to prevent condensate water from freezing in the pipe, which could prevent the correct operation of the unit.

## Location of the unit



- ▶ For systems using flammable refrigerants, no refrigerant leaks will flow or stagnate. Failure to comply with this requirement may result in a fire or explosion hazard in areas within the unit containing components and devices which may be a source of ignition.
- ▶ The use of tools that generate sparks must be strictly avoided within the safety area.
- ▶ The unit **MUST** be installed in a safe location, exclusively outdoor, in an area free of obstacles for ventilation and maintenance and free from any sources of open flames. Access must be provided for ordinary and extraordinary maintenance of the unit.
- ▶ The installation area must therefore be delimited and with access reserved for authorized persons only.
- ▶ Maintain clearances for service and safety around the unit as shown in "Clearances" on page G-19. In case of stricter national regulations, follow those regulations.
- ▶ It is very important to avoid recirculation phenomena between air inlet and air outlet, otherwise the performance of the unit will be degraded or even normal operation will be interrupted. In this respect, it is necessary to ensure the minimum service spaces, refer to "Clearances" on page G-19.

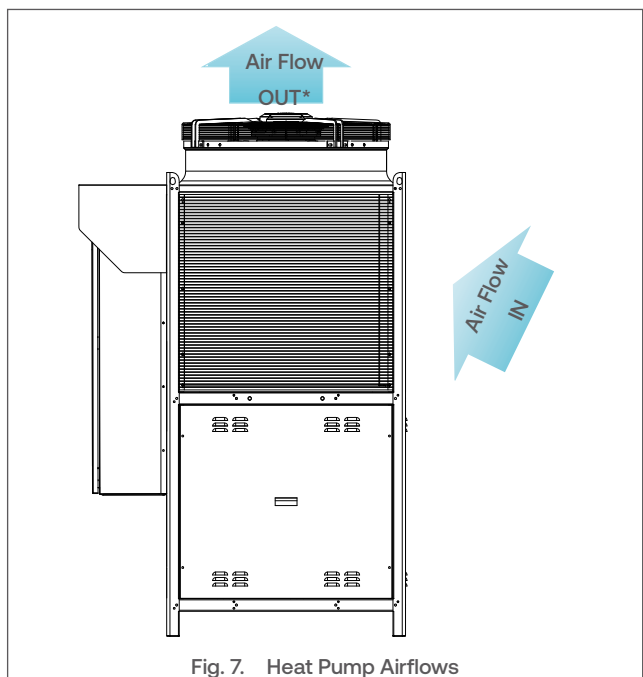

Fig. 7. Heat Pump Airflows



- ▷ The units transmit a low level of vibration to the ground; it is therefore recommended to interpose anti-vibration mounts between the base frame and the ground plane. Refer to "Installing Anti-Vibration Dampers" on page I-38.
- ▷ It is recommended to install the outdoor unit in a free-standing position on a fixed substructure with a height of at least 350 mm.
- ▷ The unit must be installed in an open space with the required airflow and in a way that prevents the recirculation of outside air. The direction of airflows is shown in Fig. 7.
- ▷ In the defined safety area around the product, there must be no manholes, basement entrances, windows or doors communicating with areas below the unit installation level where open flames are present or where there is no mechanical or natural ventilation.
- ▷ In their standard configuration, the units are not suitable for installation in saline environment.
- ▷ The installation of units below lower ground level is only permitted if a refrigerant sensor and automatic ventilation system are installed. If the elevation profile of the ground level is oblique with respect to the floor of the installation area and is partly lower than the floor, the installation is allowed if there are no obstacles towards the lower ground level.



- ▷ It is recommended to install an anti-snow roof to prevent gathering snow on the unit. See Fig. 8.
- ▷ The units, in their standard configuration, are not suitable for installation in saline environment.
- ▷ If the unit is installed in windy areas, where the wind speed is greater than 2,5 m/s (9km/h), in order to prevent malfunctions, it is necessary to use wind barriers (see Fig. 9) or increase:
  - ▷ the distance between the heat pumps by 0,8 m, and
  - ▷ the distance between the wall and the heat pump by 0,5 m

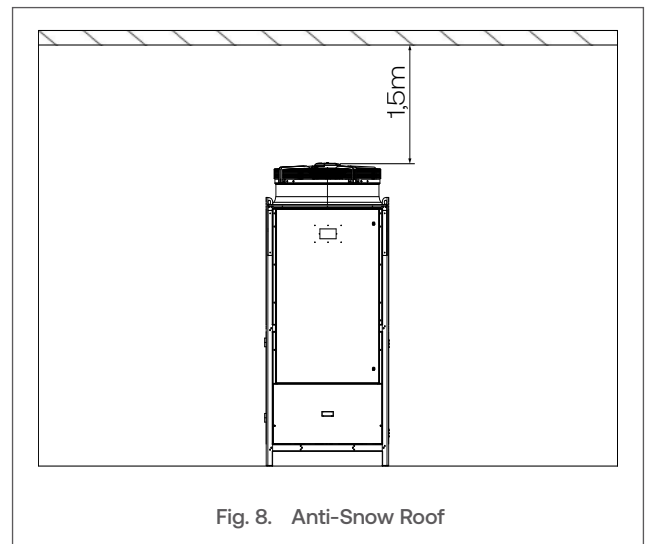

Fig. 8. Anti-Snow Roof

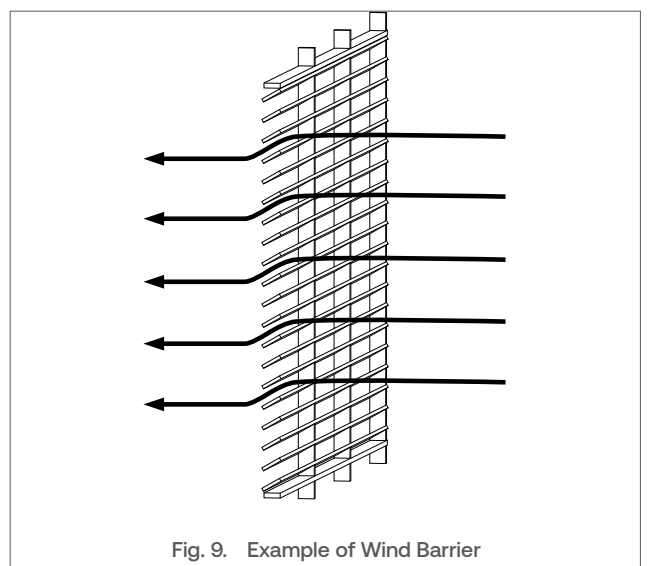

Fig. 9. Example of Wind Barrier

## PRODUCT INSTALLATION

### Installing Anti-Vibration Dampers

**Safety requirements :**



**Tools and materials:**

- › Bubble level
- › Adjustable wrench

**Procedure:**

1. Before lowering the unit to the ground, install interfacing anti-vibration dampers to the feet of the unit.
2. Once the unit is on the ground, ensure that the unit is level.
3. Adjust feet height if required.

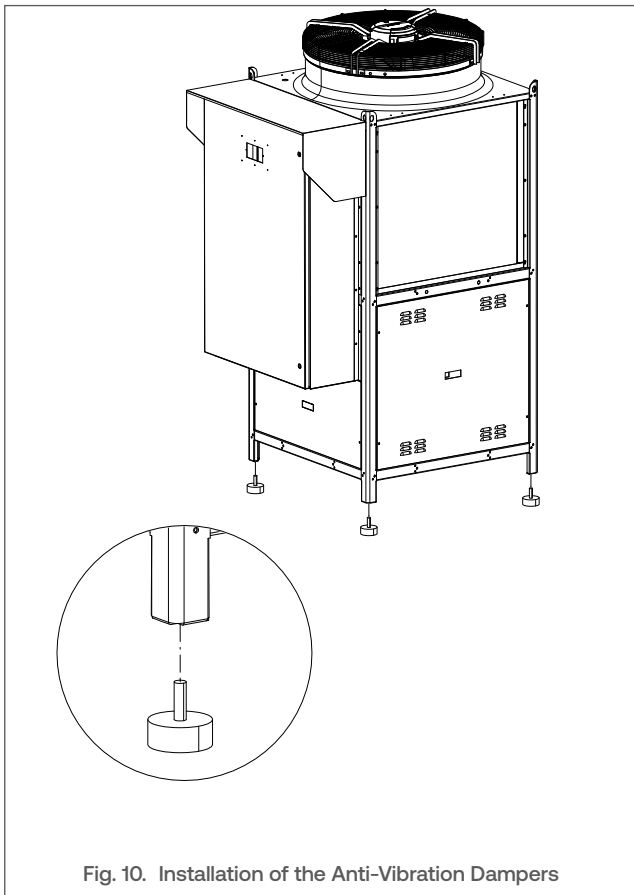

### Opening and Closing the Access Doors

**Conditions:**

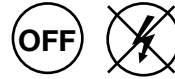

**Tools and Material:**

- › Key supplied with the heat pump
- › Wrench, flat, size 10

**Removal Procedure:**

**Top Front door(s) and Controller Door**



To be able to open the top door, make sure that the emergency power switch is set to OFF.

1. Using a key, rotate the lock (1).
2. Open the door on its hinges.
3. Perform procedure in reverse order to close the door(s).

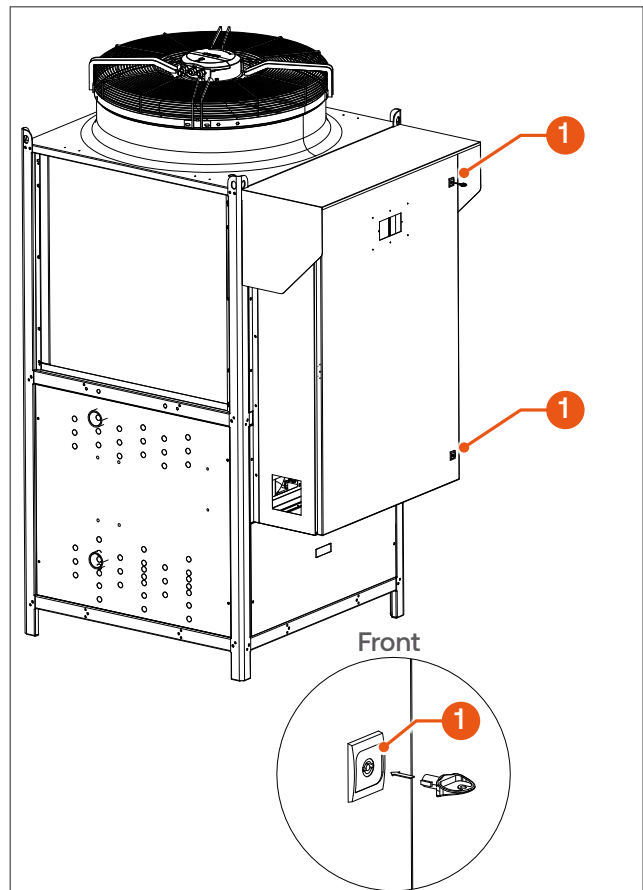

**Side and Rear Access Doors**

1. Using a wrench, remove the screws (2) around the access door. Retain for reinstallation.
2. Lift the access door using the built-in holder (3) and set aside.
3. Perform procedure in reverse order to close the door(s).

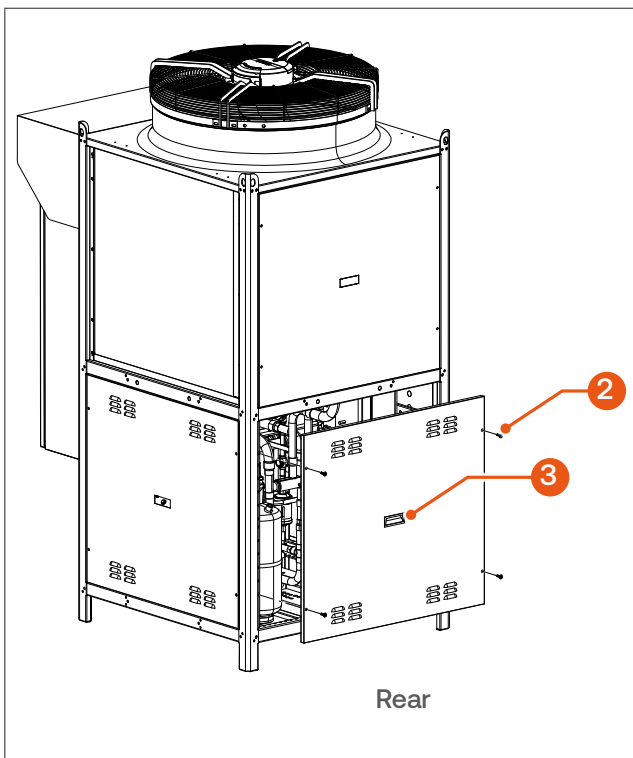

Safety Instructions for the Hydraulic Connections

Primary Circuit



Make sure that the circuit is provided with a safety pressure relief valve (PRV) and an expansion vessel that is appropriate for the system size and unit power, and the increase in temperature and pressure.



Any antifreeze used in the primary circuit must comply with Public Hygiene Regulations and must be non-toxic. A food-grade Propylene Glycol is recommended. It must be diluted according to the ratio recommended in the local regulations and in percentage appropriate to the operating conditions of the unit (evaporating temperature).



- ▶ The pressure of the water network used to fill the appliance must be at least 2 bar.
- ▶ If the pressure is higher than 6 bar, the system will be protected by a water safety valve set to 6 bar.
- ▶ Verify the water quality of the network according to the requirements defined in this manual.
- ▶ In case inhibitors are used in the system, consult the manufacturer for product suitability.



- ▶ *The use of antifreeze in the primary circuit will lead to a reduction in the heating performance. The higher the concentration of antifreeze in the circuit, the lower the performance. Maximum output must be adjusted accordingly.*
- ▶ *The circuit diagrams are theoretical representations that do not necessarily include all the required safety devices. Make sure to correctly plan your system according to the applicable local regulations and standard practices.*

Domestic Hot Water Circuit



▶ Make sure that the circuit is provided with a safety group.

▶ Depending on the type of unit and the defined setpoint, the temperature of the hot water produced in a DHW circuit can reach 60 °C and cause scalding when drawn from a tap. The installation of a thermostatic mixing valve is therefore recommended.



- ▶ Flush thoroughly the circuit before operation.
- ▶ DHW circuit piping should be made from copper or galvanized steel.



- ▶ *The installation of an expansion vessel in the DHW circuit is recommended to prevent the water hammer effect in the pipework and the frequent opening of the safety valve.*
- ▶ *The circuit diagrams are theoretical representations that do not necessarily include all the required safety devices. Make sure to correctly plan your system according to the applicable local regulations and standard practice.*



- ▶ The pressure of the water network used to fill the appliance must be at least 2 bar.
- ▶ The supply pressure from the network must be comprised between 2 and 6 bar. If the pressure is higher than 6 bar, the system must be protected by a water safety valve set to 6 bar.

Requirements for the Hydraulic Connections



**When restarting the unit after a long stop period, verify the circulation pump(s) is operating, if any is installed. If the pump is blocked by limescale, turn it by hand moving the back side cooling fan after removing the back protection cover.**



▶ **Install the water pipes in accordance with national and local regulations.**

- ▶ Pipes can be made from copper, steel, galvanized steel or PVC. Design the pipe work to meet the nominal water flow and hydraulic pressure drops of the system. The maximum pressure drop is typically of 300 Pa/m.
- ▶ Insulate all pipes with closed-cell material of adequate thickness.
- ▶ Make sure to fit the system return water to the connection labelled: "WATER INLET". An incorrect connection can damage the heat exchanger by freezing.
- ▶ The WATER INLET connection must be fitted with a water strainer which mesh is not larger than 1 mm. Failure to comply will invalidate the warranty.
- ▶ Make sure to check the filter regularly and keep it clean.
- ▶ In standard configuration, a flow switch, provided with the unit, must be fitted to the connection labelled "WATER INLET". Failure to comply will invalidate the warranty.
- ▶ Do not allow the water flow through the heat exchangers of the unit to fall below  $\Delta t=8^{\circ}\text{C}$ . Measurement conditions:
- ▶ Heating mode:  $7^{\circ}\text{C}$  Dry bulb ambient temperature,  $35^{\circ}\text{C}$  water outlet temperature;
- ▶ Cooling mode:  $35^{\circ}\text{C}$  dry bulb ambient temperature,  $7^{\circ}\text{C}$  water outlet temperature

To lengthen the life of the unit and hydraulic circuits, it is recommended to install the following equipment:

- ▶ 2 pressure gauges of the correct scale (inlet and outlet),
- ▶ 2 shut-off valves (inlet and outlet),
- ▶ 2 antivibration connections (inlet and outlet),
- ▶ 2 thermometers (inlet and outlet).
- ▶ 2 air relief valves
- ▶ a Y metal filter on the inlet only (See Fig. 11 for the correct position of installation)
- ▶ A flow switch on the inlet
- ▶ An additional expansion vessel if the volume in the system requires it.

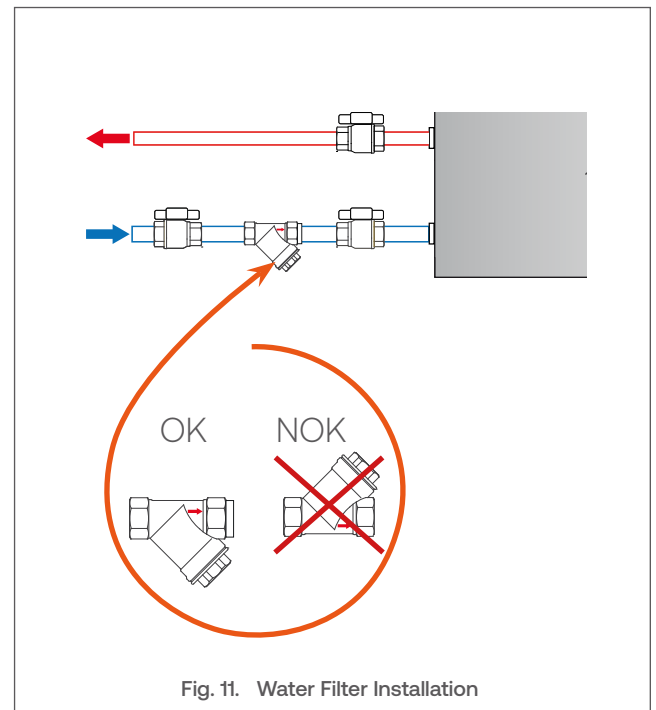

Fig. 11. Water Filter Installation



See the following pages for examples of standard heating/cooling systems and DHW production systems.

# PRODUCT INSTALLATION

## Flow Switch Installation

Conditions:  

Safety requirements:  

### Tools and Material:

- ▶ 2 nylon gaskets
- ▶ 2x adjustable wrenches
- ▶ Sealing material (hemp and sealing paste or teflon tape)

 All units are supplied with a paddle flow switch mounted on a tee connection, which should be installed on the heat pump return connection, labelled "WATER INLET".

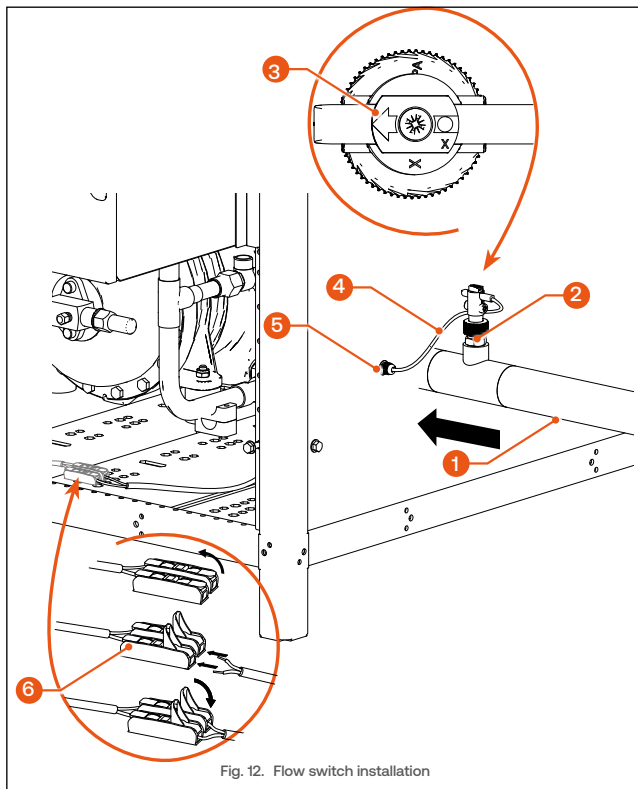



Fig. 12. Flow switch installation

### Procedure:

 To prevent any fluctuations in the flow, avoid bends, other fittings, valves, drains, or wider sections of pipe, and any other features within a distance of 5 times the internal pipe diameter upstream of the flow switch. It is therefore recommended to install a straight section of pipe.

1. Install a straight section of pipe (1) upstream of the flow switch (2), with a minimum length of 5 times the internal diameter of the pipe.
2. Seal the thread with suitable sealing material (e. g. hemp or Teflon tape).
3. Screw the flow switch and tee connection assembly (2) to the pipeline. Make sure that the arrow (3) indicating flow direction on the top of the flow switch is pointing towards the heat pump.
4. Route the flow switch wires (4) through the cable gland (5) labelled "FLOW SWITCH" and connect to the dedicated terminals (6) inside the heat pump:
  - ▶ Strip a piece of insulation from the wire ends to ensure a good electrical connection inside the terminal block.
  - ▶ Lift the terminal block levers upwards and insert each stripped wire end into a terminal of the block (6).

 Wires can be connected indifferently to the terminals.

- ▶ Lower the terminal block levers to secure the wires. Check visually that the connection is secure. Also refer to the following page for more information regarding the electrical connection.

### Follow-on Task(s):

1. Start the appliance as required. Refer to "Start-up and Commissioning" on page I-53.
2. Check that there are no leaks. If required, seal the pipeline and tee connections.

### Typical Hydraulic Connections - Primary

Pipelines must be carefully sized according to the unit's nominal water flow rate and the pressure drop in the hydraulic circuit.

The liquid velocity should be kept below 2 m/s. If the optional single pump kit has been provided, the residual head of the pump should be checked. Please refer to **"Single pump kit"** on page G-13.

All hydraulic connections must be insulated with closed-cell material of adequate thickness.

The unit must be connected to the pipeline using appropriate flexible couplings: rubber expansion compensators.

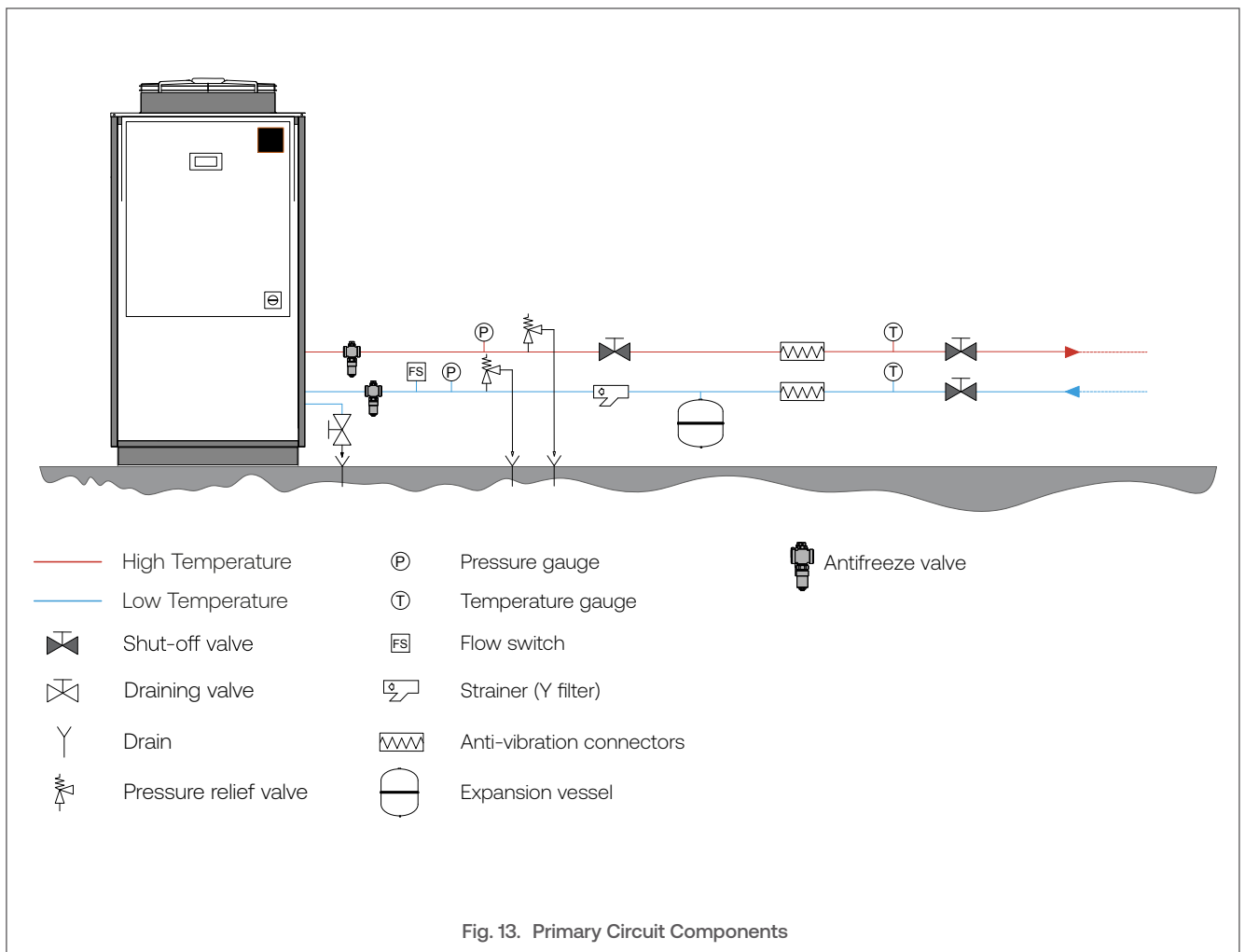

# PRODUCT INSTALLATION

## System for the Production of DHW / Heating / Cooling

### 2 Pipe system

The system uses water stored in the buffer tank. This water is maintained at a temperature up to 58 °C which is sufficient to prepare DHW and radiator/fan coil flow temperatures in an efficient way. With addition of buffer tank, the heat pump will work continuously without frequent starts and stops of the compressors,

which adds to the system longevity. In summer, when the user requires chilled water, the heat pump is in cooling mode and switches to heating mode when the preparation of DHW is demanded.

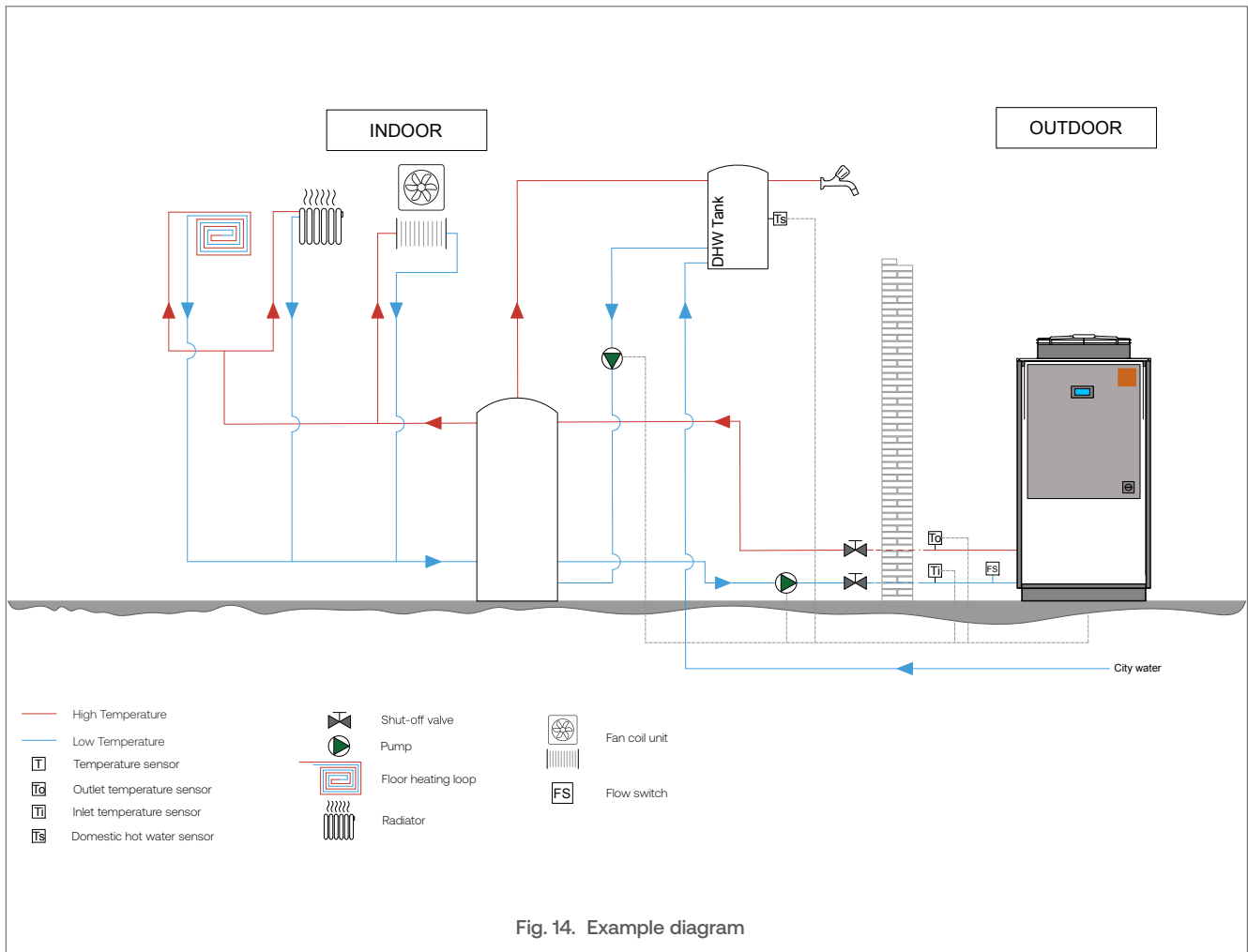
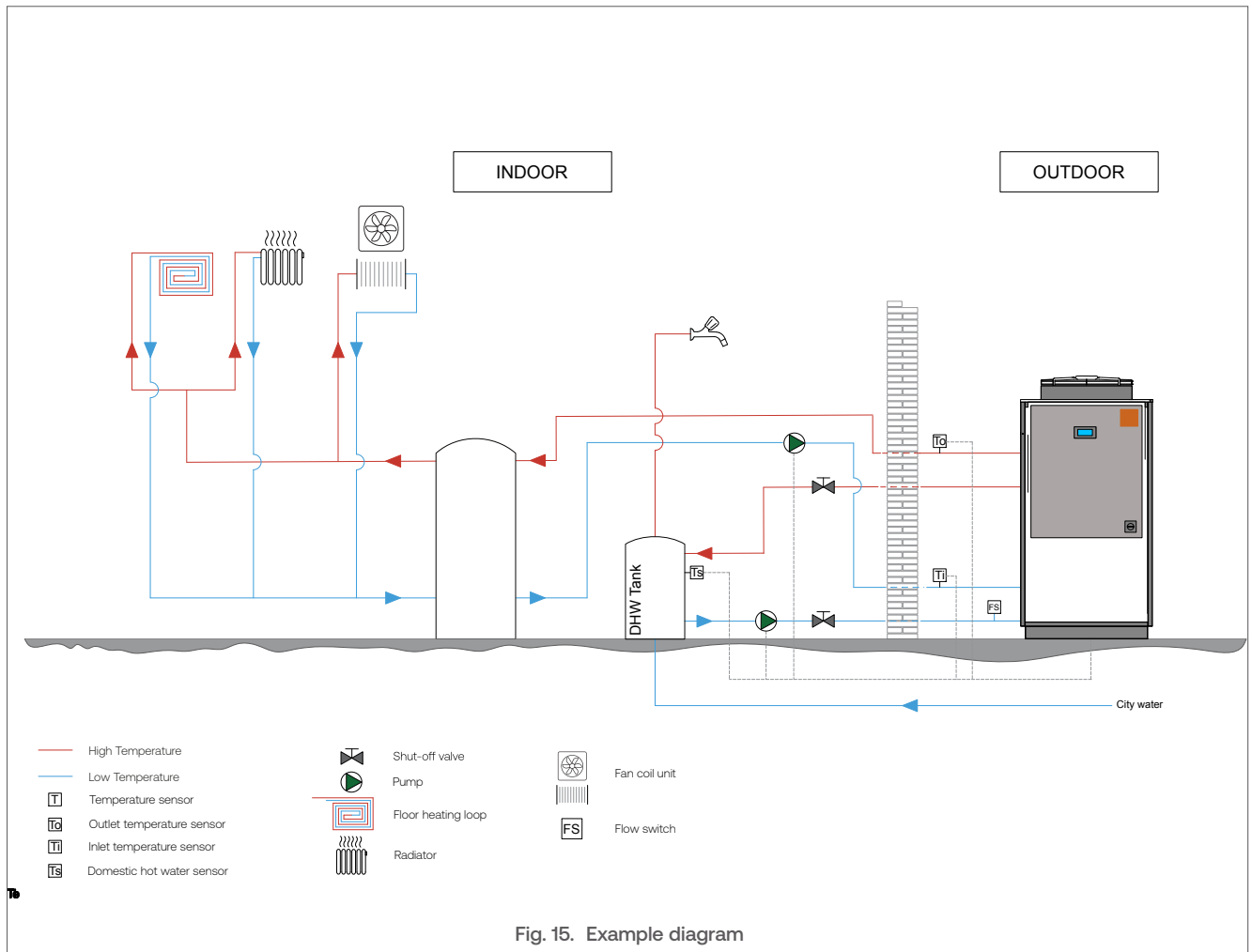

Fig. 14. Example diagram

**4 Pipe system:**

This solution is best suitable for buildings with existing heating systems that benefit from heat pump retrofit. It involves using the existing domestic hot water tank with internal coil heat exchanger, and existing underfloor heating system. The hot water stored in the buffer tank

can be used for floor heating/radiator/fan coils. In summer this solution allows user to simultaneously prepare DHW temperature while the heat pump is in cooling mode utilizing heat produced during cooling.



*The heat pump has to be connected to the buffer tank. This is required to guarantee the correct operation of the unit, avoiding frequent start and stops of the compressors. Please contact your AIC representative for correct sizing of the buffer tank.*

# PRODUCT INSTALLATION

## Safety Instructions for the Electrical Connections



Electrical connections must be carried out by a qualified professional in accordance with current standards and regulations in force.



- ▶ When connecting wires to the terminals, check that the connection is secure and that all the cable strands are tightly held.



- ▶ When the unit is connected to the electrical network, it must be earthed.
- ▶ Make sure that a fuse or circuit breaker of the recommended rating is installed outside the unit, to allow electrical isolation.
- ▶ Do not touch the unit with any wet body parts when it is supplied with electrical power.
- ▶ Before performing any operation on the electrical circuit, isolate the electrical supply of the unit through the external power-cutting device (fuse, circuit-breaker, etc.)
- ▶ When routing the cables through sharp-edged holes in the panels, make sure to install glands or grommets, and to secure the cables in order to prevent any damage.

## Power supply connection

1. Grounding PE connection.
2. High Voltage wiring is connected to a main switch, located in the heat pump electrical box.
3. External interface terminal block.

The main board and the low-voltage terminal strip are also located at the front of the heat pump.

## Wirings optional connections

All the units are equipped with the controller that can be connected to BMS remote control system using the Modbus protocol. For information on the number of terminals required to connect the BMS control system, refer to the wiring diagram supplied to the unit.



**Signal or control wires (dry contact) must be electrically separated from power cables.**

When connecting the external water pump to the unit, the control and alarm terminals shown "**Terminal Block Connections**" on page I-47 must be used.

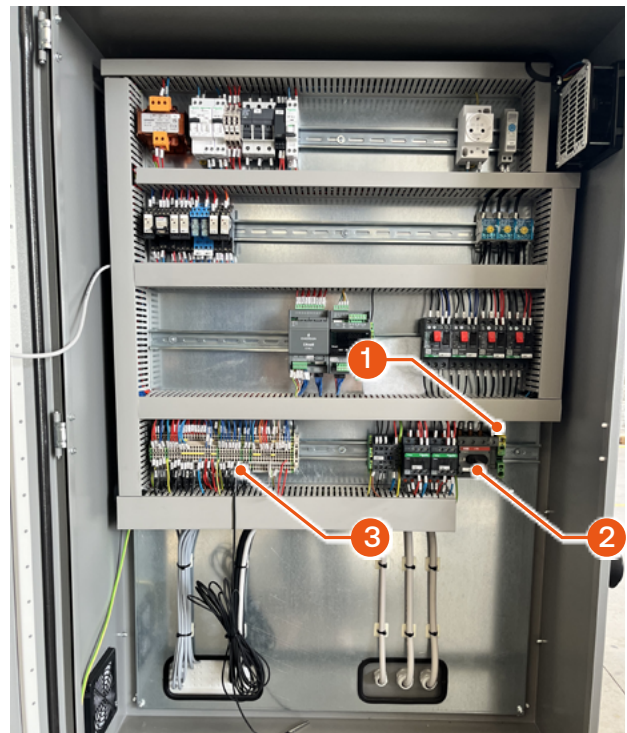

Terminal Block Connections

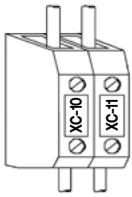

**REMOTE ON/OFF (dry contact)**

Terminals : XC-10 / XC-11.

Closed contact: unit ON.

Open contact: unit OFF.

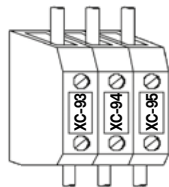

**REMOTE Display connection**

Terminals : XC-93 / XC-94/ XC-95

Cable type: 3x1 mm<sup>2</sup> shielded

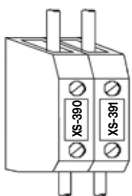

**AMBIENT air temperature(signal)**

Terminals : XC-390 / XC-391.

Sensor type: NTC 10 kΩ

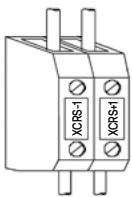

**RS485 Connection(signal)**

Terminals: XCRS-1 / XCRS+1

Cable type: 2x0,75 mm<sup>2</sup> twisted pair

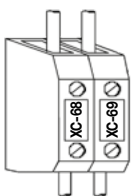

**REMOTE SUMMER/WINTER SWITCHING (dry contact).**

To use a summer/winter remote switching device, the jumper must be replaced with a switch connected to terminals XC-68 / XC-69.

Closed contact: unit in WINTER.

Open contact: unit in SUMMER.

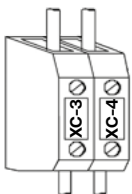

**OPTIONAL EXTERNAL WATER FLOW SWITCH (dry contact).**

To connect the external paddle flow switch contact, the jumper must be replaced with the contact at terminals XC-3 / XC-4.

Closed contact: flow not present.

Contact open: flow present.

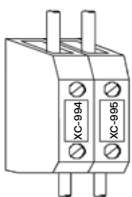

**CONTACT ENABLING DOMESTIC WATER ONLY (dry contact).**

Terminals: XC994 / XC995.

Closed contact: enable.

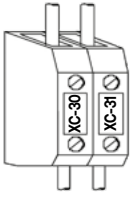

### REMOTE GENERAL ALARM (dry contact)

For remote signalling of a general alarm, connect an audible or visual device between terminals XC-30 / XC-31.

Contact closed: unit in alarm.

---

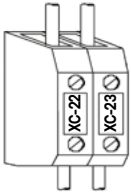

### DOMESTIC HOT WATER PUMP (230V/2A)

Terminals: XC-22 / XC-23.

---

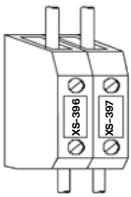

### DOMESTIC HOT WATER TANK

Terminals: XS-396 / XS-397.

Sensor type: NTC 10 k $\Omega$

---



*The numbering of terminals may change without notice. Please always refer to the wiring diagram supplied with the unit.*

## RS485 Serial Interface Card as Standard

Connection for interfacing to supervisory system, allows remote monitoring of all operating parameters of the unit and changing their values. It is necessary to observe the polarity of the wiring. Any reversal in polarity may result in the unit malfunction. The cable of the supervision connection must be the two-core twisted pair cable with a cross section of at least 0,75 mm<sup>2</sup> and maximum length 200m.

The unit is factory configured with serial address 1. When using MODBUS system, the list of variables can be obtained by contacting the service.

## Installing a Remote Control Panel



- ▶ Special care must be taken when connecting the keyboard to the controller, in order to avoid irreparable damage to the PCB and/or control panel.
- ▶ In case of power supply failure, the control panel will not work.
- ▶ In case of communication problems, the display will show “noL” message.
- ▶ If an external display is used, disconnect built-in display.

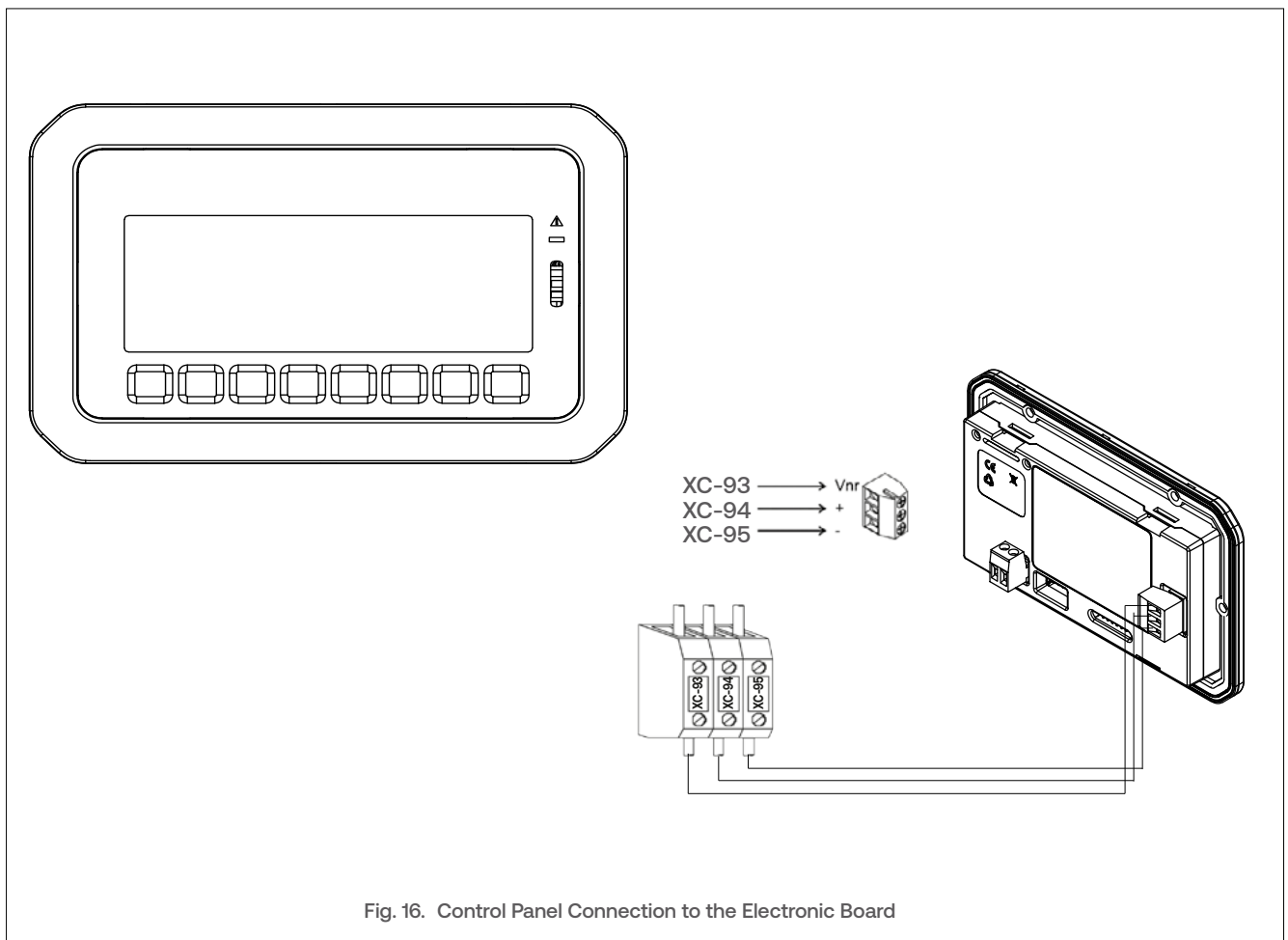

*The complete wiring diagram is provided with the unit.*

# PRODUCT INSTALLATION

## Refrigerant Circuit Layout

### 2 Pipe system

This version uses 2 hydraulic connections and is capable of producing hot water in the winter period, cold water in the summer period, and domestic hot water throughout the year. The unit should be combined with a 2-pipe system and connected to an external 3-way valve (not supplied) for priority domestic hot water production.

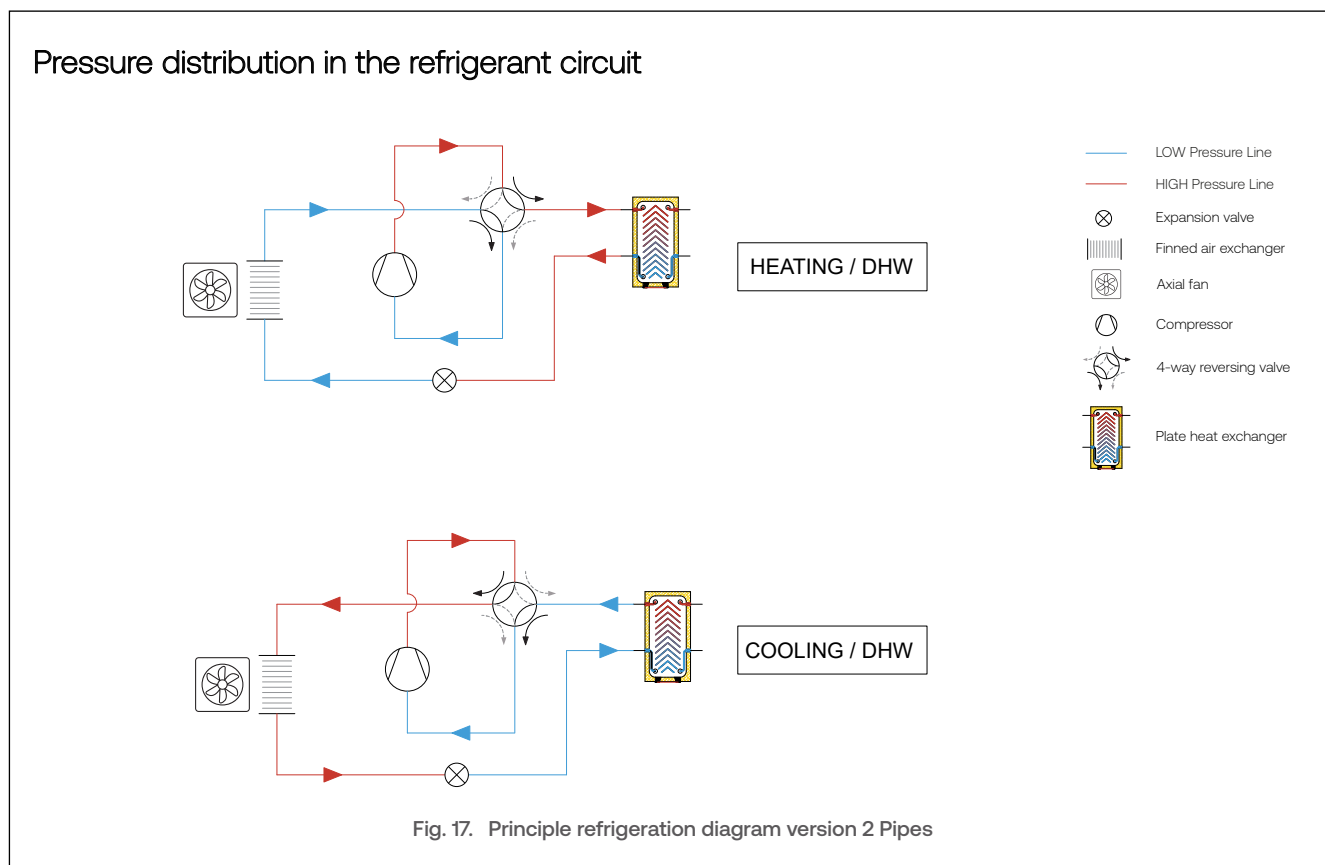

### 4 Pipe system

This version uses 4 hydraulic connections and is capable for producing hot water in the winter period, cold water in the summer period, and domestic hot water throughout the year. The unit should be combined with a 4-pipe system. Comparing to 2 pipe system, it has 2 additional connections dedicated for domestic hot water (external 3-way valve is not required). 4

pipe system has additional plate heat exchanger in refrigeration circuit which can produce both: cold water for air conditioning and DHW at the same time. The heat coming from cooling is utilized to heat up DHW.

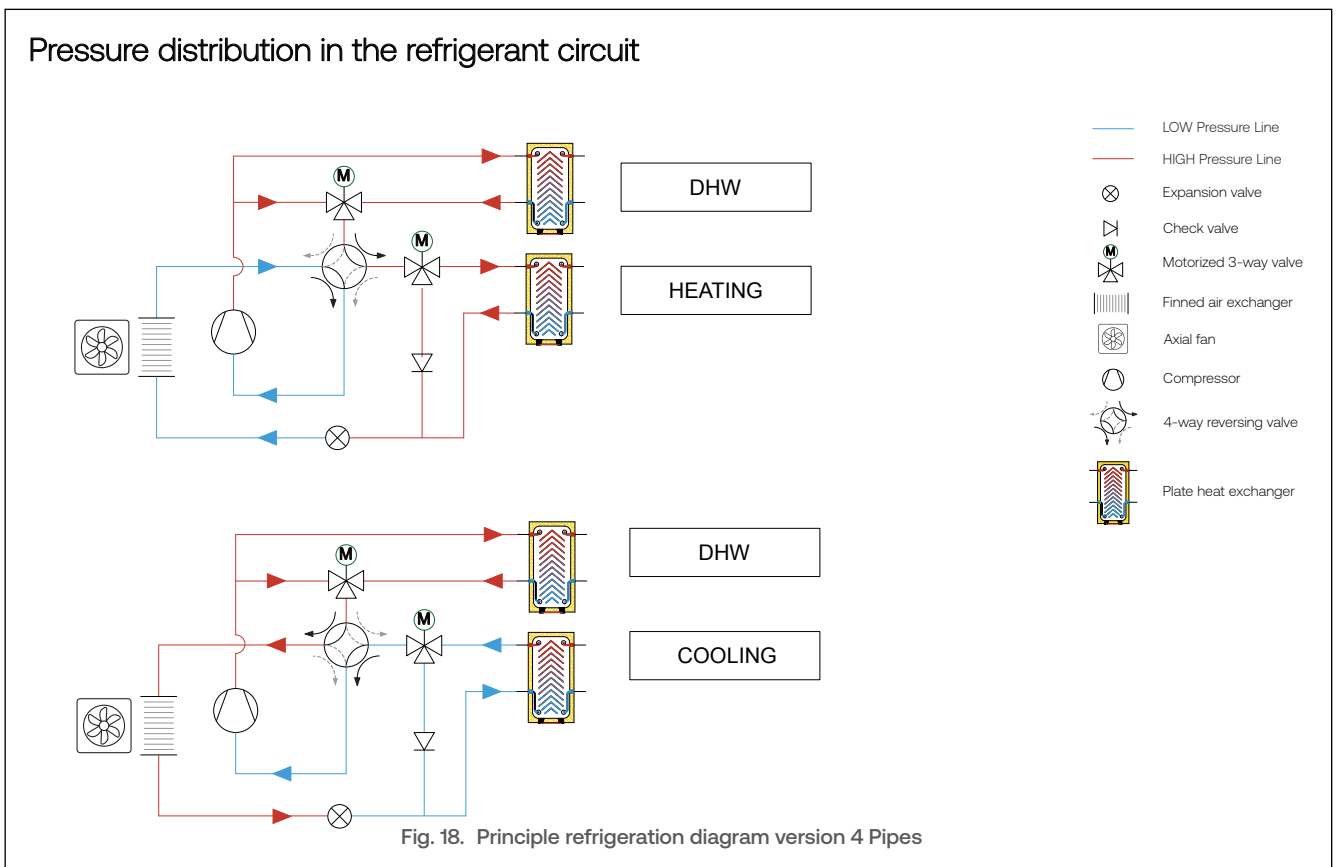

Safety Instructions Before Start-up



Check that all connections (electrical, hydraulic) have been carried out and that they are tight and secure.



- ▶ Make sure that the unit is connected to electrical power supply at least 24 hours before starting it up.
- ▶ Before starting the unit, check that the hydraulic circuits are full of water and that the unit is supplied with electrical power.

- ▶ Before the first startup of the heat pump, install and connect the flow switch in the system.
- ▶ Check that there is no refrigerant leakage and that all taps are open.
- ▶ Check that there are no oil stains, sign of a possible leak.
- ▶ Check that the water pressure is sufficient in the user water circuit (at least 1,5 bar when cold). Top up the circuit as required.
- ▶ If frequent top-ups are necessary, check for leaks and repair as required.
- ▶ Once the filling of the heating circuit is complete, close the filling valve.



Once the initial start-up process is complete, fill in the installation checklist with all the relevant information on the system for future reference.

Filling the System

Conditions:



Procedure:

1. Connect water supply to the filling valve.
2. Open all system manual air vents. Heat pump unit has automatic air vent installed, therefore opening unit enclosure is not required. The black cap (1) is unscrewed by 1 turn.

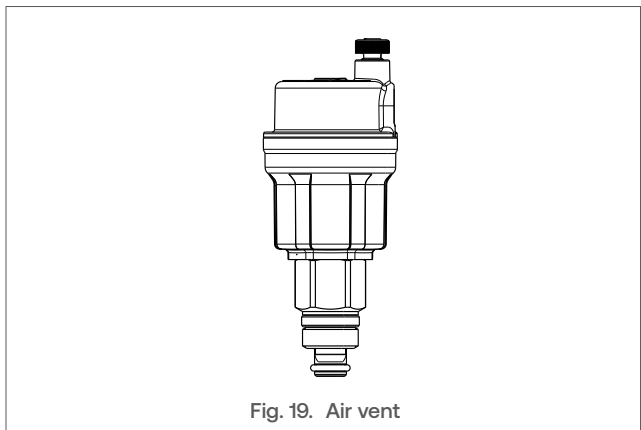

Fig. 19. Air vent

3. Open all shut off valves and ensure that the system is open to one volume.
4. Slowly open the filling valve and water supply flow valve.
5. Keep filling.
6. When water begins to leak out of the air vent valves, close them, and continue filling until the pressure gauge indicates a pressure of 1.5 bars (when the water is cold the pressure should be between 1,5 and 3 bar).
7. If the pressure in the system exceeds 3 bar, close the water supply valve and open drain connection until the pressure is between 1,5 and 3 bar.
8. After the whole system is filled with water of correct pressure, close the filling valve and disconnect water supply.

Follow-on Task(s):

None



Restarting the unit after a long period of inactivity, verify if the pump is operating, if installed. If the pump is blocked by limescale, turn it manually by moving the cooling fan on the back after removing the back protection cover.

## Start-up and Commissioning



- ▶ All initial checks have been carried out. Refer to "Safety Instructions Before Start-up" on page I-52



**Procedure:**

1. Make sure that shut-off valves on the refrigerant side (if presented) are open in the appliance before starting up.
2. Energise the unit through the dedicated fuse(s) on the electric box.
3. Make sure that the Emergency switch is in ON position.



- ▶ **Never use the emergency switch to turn the unit on and off; it should only be used in emergencies to disconnect the unit from the power supply when it is to be permanently off. Isolation will result in no supply for the crankcase heater and the compressor could be seriously damaged at start-up.**

- ▶ **It is important to let the heat pump reach the set point and then start up the system terminals. In the case of a single hydraulic circuit in which only one water pump circulates water, keep all terminals closed or switched off until the heat pump switches off due to reaching the set point. Then leave the terminals in automatic mode.**
- ▶ **In the case of separation of the primary circuit (heat pump to water tank) and the secondary circuit (water tank to terminals), keep both the secondary circuit pump and the terminals switched off.**
- ▶ **Switch on the heat pump until the set point is reached, then set the operation of the secondary circuit pump to automatic, and finally set the consumers to automatic.**

4. Press the key corresponding to the Heating  or Cooling  mode located on the control panel. The corresponding icon will appear on the screen. Refer to "Operation Modes" on page I-625 for more information on the available modes.
5. Perform the setup of the system as required. Refer to "Set points" on page I-62.
6. Check the operation of the compressors and fans by measuring the electric consumption of each component.
7. Open the bottom front door to access the pressure and temperature gauges of the high-pressure and low-pressure service ports. Refer to "Opening and Closing the Access Doors" on page I-38.
8. A few minutes after start up, check that the equivalent temperature of the refrigerant gas, measured at the pressure inside the finned coil with fans running at full speed, differs from the outside air temperature of about 7-10 °C.
9. Verify that the saturated temperature of the refrigerant gas, measured at the pressure in the plate heat exchanger, differs from the heat exchanger water outlet temperature of about 3-5 °C.
10. After several hours of operation, check that the sight glass has a green colour core. If the core is yellow, moisture is present in the circuit.
11. Regularly clean the water filter.

**Follow-on Task(s):**

Close all open doors, refer to "Opening and Closing the Access Doors" on page I-38.



*At full speed, check that the current consumption complies with the limits of the plate expressed in the case of abnormal consumption turn off the fan and contact our support department*

## Safety Requirements for Maintenance



- ▶ Inspection and maintenance tasks must be carried out by a qualified and certified professional according to the frequency indicated in the maintenance table provided in this manual.
- ▶ Make sure to perform all obligations:
  - ▶ Keep records of the equipment, specified in Logbook.
  - ▶ Carry out the correct installation, maintenance and repair of equipment.
  - ▶ Perform regular leakage control.
  - ▶ Perform refrigerant recovery and disposal management.
- ▶ Once the inspection and maintenance tasks are complete, ensure that all removed components are reinstalled and all connections are tight and secured.
- ▶ Always wear appropriate personal protective equipment to perform maintenance or repair tasks, see “Health and Safety – Hazard and prevention”. The antistatic clothes and charge-dissipating wristbands should be used.
- ▶ When working on the unit, smoking and the presence of any other open flame or ignition source is strictly forbidden.
- ▶ During work on the refrigerant circuit, ensure well-ventilated area; the atmosphere must be monitored using a suitable gas detector.
- ▶ Tools and measuring devices that may come into contact with the refrigerant or its mixture with air must not cause ignition.
- ▶ Be aware that a cell phone, E-cigarettes or similar electronic devices could be a source of ignition.



- ▶ Before performing any maintenance operation, shut down the unit using the appliance on/off switch and isolate the electrical supply of the appliance through the external power-cutting device (fuse, circuit-breaker, etc.), unless power is required for the procedure (it will then be indicated in the procedure).
- ▶ Do not touch the unit with any wet body parts when it is supplied with electrical power.



- ▶ The maintenance of the unit and its components must be carried out by a qualified professional.
- ▶ Defective parts and components may only be replaced by genuine factory parts or parts approved by the manufacturer.
- ▶ Replace any gaskets or seals present on the removed components before reinstallation, unless otherwise specified in the procedures.
- ▶ Shut-off valves in the refrigerant circuit need to be closed for maintenance, make sure to tag the taps in order to indicate that they are closed. All tagged manual shut-off valves must then be reopened before start-up of the unit.
- ▶ To ensure the performance, durability and reliability of the unit, it is recommended that the end-user perform the periodic checks. *Please refer to “Safety Instructions for the User”* mentioned in the Safety section for the user, at the beginning of this manual.
- ▶ The minimum pressure of the primary circuit is between 1,5 and 3 bar when cold.
- ▶ If the water circuit needs to be topped up, allow the unit to cool down and only add small quantities of water at a time. Adding a large quantity of cold water in a hot appliance can damage the appliance permanently.
- ▶ If the unit remains unused during the winter period, the water contained in the pipes may freeze and cause serious damage. Fully drain the water from the pipes, checking that all parts of the circuit are empty including any internal or external traps and siphons.
- ▶ If leak detection instruments are installed on the system, they must be inspected at least once a year, to ensure their correct operation.



*The inspection and maintenance tasks are detailed in a tables in this section. Make sure to perform all the recommended tasks and to fill in the logbook available from your AIC technical representative with all the required information.*

### Maintenance Requirements



To perform maintenance, connect to the **aicON** application and fill in all the relevant information. Refer to the back cover of the manual for easy access. Please contact your AIC representative for more information about this app.

Safety requirements:



Caution :



Tasks	Visual inspection	Pressure test	Leaks
Intervention with possible effects on the mechanical strength or after use change or in case the machine has not being working for more than two years.	X	X	X
Replace all the components which are not suitable any more. Do not carry out checks at a higher pressure than the one indicated in the project.			
Repair, or significant adjustments of the system, or its components.			
The check may be limited to the interested parts, but if a leakage of refrigerant is detected, a leakage search must be carried out on the entire system.	X	X	X
Leak search, following a well-founded suspicion of refrigerant leakage.			
It is recommended to examine the system for leakage, either directly (use of leak detection systems) or indirectly (deduction of leakage based on analysis of operating parameters), focusing on the parts most prone to leakage (e.g. connections)	X		X



**If a defect is detected that compromises the reliable operation of the unit, the unit cannot be re-started until it has been repaired.**

# MAINTENANCE

## Specific Maintenance Tasks

Tasks	Months		Years
	1*	6	1
			
<b>Electrical System</b>			
Check that the unit works properly and that there are no active warnings	X		X
Visually inspect the unit	X		X
Check noise and vibration level of the unit			X
Check operation of safety features and interlocks			X
Check the unit's performance			X
Check the current draws of the different parts (compressors, fans, pumps, etc.)			X
Check tightness of high voltage connections			X
Visually check the insulating coating of power cables			X
Clean the electrical and electronic components of any dust			X
Check the functioning and settings of probes and transducers			X
Check the correct positioning of 3-way motors on 3 way valves, if present			X

\* 30 days after start-up

Safety requirements:    

Tasks	Months		Years
	1*	6	1
			
<b>Condensing coils and fans</b>			
Visually inspect the coil	X		X
Clean finned coils		X	X
Check the water flow and/or any leaks	X		X
Check that the flow switch is working properly (refer to Troubleshooting)			X
Clean the metal filter on the water line		X	
Check the supply voltage of the fans		X	X
Check the fans' electrical connections			X
Check the 3-way valve operation (if present)			X
Check the colour of moisture indicator on refrigerant liquid line			X
Check for refrigerant leaks (refer to Troubleshooting)			
Check the liquid solenoid coils (refer to Troubleshooting)			X

\* 30 days after start-up

Safety requirements:



Tasks	Months		Years
	1*	6	1
<b>Compressors</b>			
Visually inspect the compressors			X
Check the supply voltage of the compressors			X
Check the compressors' electrical connections			X
Check oil level in the compressors using the oil fill level indicator	X		X
Check that the crankcase heaters are powered and working properly			X
Check the conditions of the compressors' power cables and their tightness in the clamps			X
Check the electrical absorption of individual compressors.	X		X
Check the tightness of the nuts securing the compressor feet.			X
Check the integrity of individual compressor electrical cables.			X

\* 30 days after start-up

Safety requirements:



Tasks	Months	Years	
	6	1	5
<b>Other control activities - Check the following:</b>			
Rust on the chassis		X	
Insulation integrity		X	
Tightening collar screws		X	
Presence of anomalous vibrations		X	
Presence of alarms on controller web server (or from supervision)		X	
General check of operating values on Web server		X	
Operation of cooling fan in electrical cabinet		X	
Replace the fan filter in electrical cabinet		X	
Cleaning of machine area		X	

Safety Requirements to Repair the Refrigerant Circuit



- ▶ The heat pump contains R454B - a flammable refrigerant. Special care should be taken during handling, installation, service, cleaning and scrapping to reduce the risk of leakage and explosion.
- ▶ This procedure can only be performed by qualified professionals.
- ▶ Works must be carried out outdoors or in a ventilated area.
- ▶ Ventilation must be provided around any refrigerant outlet which should be routed outdoors.
- ▶ Always use a suitable refrigerant detector prior to and during works, otherwise a possible flammable atmosphere can occur.
- ▶ If work requiring high temperatures is to be carried out on the heat pump, a powder or carbon dioxide fire extinguisher should be on hand.
- ▶ All potential ignition sources, including smoking, should be kept at a safe distance from the service work area where combustible refrigerant can leak out. Inspect the area around the equipment before carrying out work to ensure there is no risk of ignition.



- ▶ In addition, the following measures should be ensured:
- ▶ Hoses and lines must be as short as possible to minimize the volume of enclosed refrigerant. Hoses must be in good condition and equipped with leak-proof quick couplings.
- ▶ Use fully functioning and calibrated scales.
- ▶ Refrigerant tanks must be stored in a suitable position in accordance with the instructions.
- ▶ Ensure that the cooling system is grounded before filling the system with refrigerant.



- ▶ Take special care to not overfill the refrigeration system (max. 80% of the liquid volume). Perform a system leak test after filling but before using the system.
- ▶ Before using the recovery station, check that it is working properly and has been properly maintained. Related electrical components must be insulated, to prevent ignition in the event of refrigerant leak.
- ▶ Do not exceed the containers maximum permitted working pressure.

Repair of the Refrigerant Circuit



Procedure:

When brazing is required, take the following steps:

1. Switch off the general power supply to the electrical cabinet.
- ▶ **Make sure that the system is continually grounded.**
- ▶ **Make sure that the capacitors are discharged. Discharging must be done safely, to prevent the risk of sparking.**
2. Discharge the refrigerant circuit. Refer to "Discharging Refrigerant" on page I-59
3. Purge the empty refrigerant circuit with nitrogen gas for 5 min.



**Parts to be replaced should be removed by cutting, not by flame.**

4. Purge the braze point with nitrogen gas during the brazing procedure.
5. Carry out a leak test before charging with refrigerant.
6. Reassemble sealed enclosures carefully. If seals are worn, replace them.
7. Check the safety of the equipment before putting it into service.

Follow on task(s):

None



Regarding fluorinated gases, the operator responsible for charging and discharging operations of the refrigerant gas must be F-GAS licensed. This license certifies that the operator is aware of the procedures. These operations must be carried out exclusively by qualified personnel only.

### Discharging Refrigerant



- ▶ Tools and measuring devices that may come into contact with the refrigerant or its mixture with air must not cause ignition.
- ▶ Before starting the procedure, inform all persons nearby of the hazardous nature of the work. Instruct them according to the "Health and Safety - Hazard and Prevention" on page G-10.
- ▶ In the event of a gas leak in the refrigerant system, even if it is only a partial leak, do not top it up. The entire system must be first emptied, the leak repaired and a new refrigerant charged into the circuit.

Safety requirements:



Caution:



Conditions:

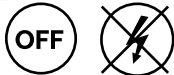

Tools and material:

- ▶ Manifold gauge set
- ▶ 5 refrigerant hoses
- ▶ R454B refrigerant tank
- ▶ Vacuum pump
- ▶ Recovery station

Procedure:

1. Connect the manifold gauge set to the low and the high pressure ports of the heat pump. Make sure the valves on the manifold set remain closed.
2. Connect the vacuum pump and the inlet of the recovery station to the remaining manifold set inlets, using hoses.
3. Connect the outlet of the recovery station to the refrigerant tank equipped with digital scale, using a hose. With the refrigerant tank, and the heat pump connectors closed, open the manifold gauge inlet up to refrigerant tank.

4. Turn on the vacuum pump allowing air and moisture to leave hoses and the equipment.
5. After 15 minutes turn the vacuum pump off and close the vacuum pump hose using valve on the manifold set.
6. Open the refrigerant tank and heat pump high and low ports.
7. Turn the recovery station on and wait until its operation is finished. It should turn off automatically after discharging is complete done. It may be necessary to wait a few minutes and repeat this step, as any remaining of refrigerant may dissolve in the oil.
8. Monitor the digital scale to monitor the charge being drawn from the heat pump and only stop recovery when there is no change in the value during the operation of the recovery station.

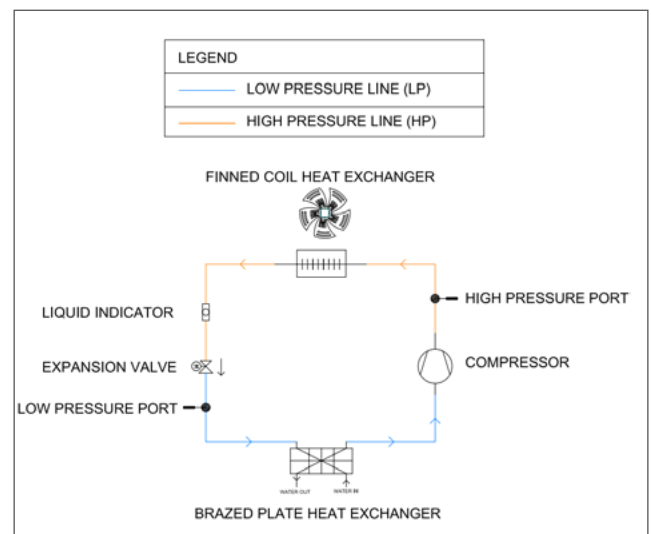

9. Once recovery is complete turn the knob on the recovery station to "purge" and operate it to ensure the recovery station is empty.
10. Close the refrigerant tank and safely disconnect the charging equipment from the unit.

Follow-on Task(s):

1. Check the tightness of the refrigerant circuit. Refer to "Leak Test of the Refrigerant Circuit" on page I-60
2. Refer to the "Disposal of the Product at the end of Service Life" on page G-29



Operators of equipment that contain fluorinated greenhouse gases, not contained in foams, shall ensure that those substances are recovered and, after the decommissioning of the equipment, they are recycled, reclaimed or destroyed.

Decommissioning



▶ The decommissioning of the unit and its components must be carried out by a qualified professional. The refrigerant charge shall be removed before decommissioning. Refer to "Discharging Refrigerant" on page I-59.

- ▶ Ensure sufficient ventilation at the equipment location.
- ▶ Be aware that malfunction of the equipment may be caused by refrigerant loss and a refrigerant leak is possible.
- ▶ Discharge capacitors in a way that won't cause any spark.
- ▶ Remove the refrigerant. If the recovery is not required by national regulations, drain the refrigerant to the outside. Take care that the drained refrigerant will not cause any danger. In doubt, one person should guard the outlet. Take special care that drained refrigerant will not float back into the building.



When flammable refrigerants (except A2L) are used, perform the following procedure:

Safety requirements:



Caution :



Conditions:



Tools and material:

- ▶ Nitrogen gas tank,
- ▶ Label with note "Refrigerant R454B removed".

Procedure:

1. Discharge refrigerant according to "Discharging Refrigerant" on page I-59.
2. Fill with nitrogen up to atmospheric pressure.
3. Place a label on the equipment indicating that the refrigerant R454B is removed.

Follow-on Task(s):

Dispose of the unit. Refer to "Disposal of the Product at the End of Service Life" on page G-40.

Leak Test of the Refrigerant Circuit



Before starting this test, discharge the refrigerant from the circuit. Refer to "Discharging Refrigerant" on page I-59.

Safety requirements:



Caution :



Conditions:

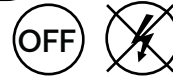

Tools and material :

- ▶ Nitrogen gas tank with pressure reduction valve and pressure gauge

Procedure:

1. Charge the system with nitrogen gas, either at the high or low pressure port, up to a pressure of 2 MPa.
2. Observe if the pressure gauge indicates a pressure drop.
3. Check all screwed connections using aerosol foam by spraying the joints. The gas leakage will be visible in the form of growing bubbles.
4. After checking the system for nitrogen gas leaks, slowly evacuate the gas from the system.

Follow-on Task(s):

1. If charging refrigerant is required, refer to "Charging Refrigerant" on page I-61



▶ Perform any repair required on the refrigerant circuit.

▶ Use a tube cutter to cut out the parts to be replaced.

▶ NEVER USE A TORCH as R454B refrigerant may still be present in the circuit.

2. Repeat the leak test of the refrigerant circuit.
3. Charge refrigerant in the circuit. Refer to "Charging Refrigerant" on page I-61.

## Charging Refrigerant

**Safety requirements:**   

**Caution:** 

**Conditions:**  



**Before charging refrigerant, make sure that a leak test with nitrogen gas has been performed and that the refrigerant circuit is tight. Otherwise, refer to "Leak Test of the Refrigerant Circuit" on page I-60**

### Tools and material :

- ▶ Manifold gauge set
- ▶ 5 refrigerant hoses
- ▶ R454B refrigerant tank
- ▶ Vacuum pump
- ▶ Recovery station

### Procedure:

1. Connect the manifold gauge set to the low and high pressure ports of the heat pump. Make sure the valves on the manifold set remain closed.
2. Connect the vacuum pump and the inlet of the recovery station to the remaining manifold set inlets, using hoses.
3. Connect the inlet of the recovery station to the refrigerant tank equipped with digital scale, using a hose.
4. With the refrigerant tank closed, open the manifold gauge inlets.
5. Turn on the vacuum pump allowing air and moisture to leave hoses and the equipment.
6. After 30 minutes turn the vacuum pump off and close the vacuum pump using valve on the manifold set.
7. Check the nameplate on the heat pump and charge the refrigerant strictly according to the labelled amount.
8. Open the refrigerant tank.
9. Turn the recovery station on and monitor the digital scale until the system is filled with desired charge.
10. Once the system is fully charged, close the refrigerant tank. Then close off the heat pump low and high pressure ports and disconnect manifold gauge set from the unit.

### Follow-on Task(s):

None

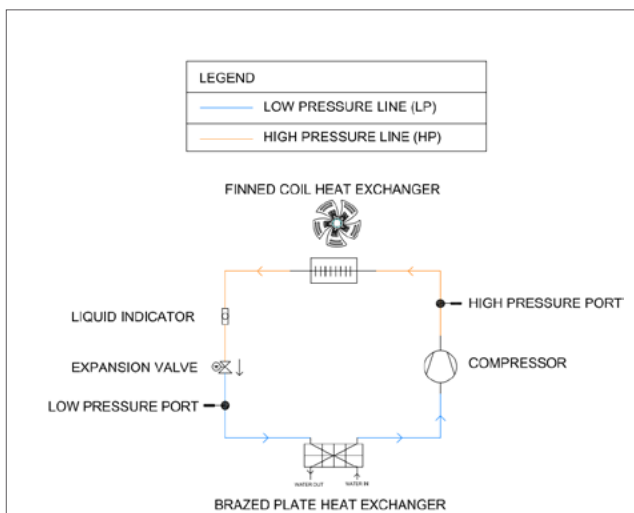

## ADDITIONAL INFORMATION FOR THE INSTALLER

### Operation Modes

#### Cooling mode

When the key  is pressed, the corresponding icon appears on the display; the Cooling mode is activated.

If requested, the compressor safety delay countdown starts and the compressor icon flashes.

The water pump will be activated after few seconds, and then, once the compressor countdown has finished, the compressor starts and the icon remains on.

The display shows the user water outlet temperature and Domestic hot water outlet temperature

#### Heating mode

When the key  is depressed, the corresponding icon appears on the display; the Heating mode is activated.

If requested, the compressor safety delay countdown starts and the compressor icon flashes.

The water pump will be activated after few seconds and then, once the compressor countdown has finished, the compressor starts and the icon remains on.

The display shows the user water outlet temperature and Domestic hot water outlet temperature.

#### Domestic hot water mode ( )

At the first start up, the unit microprocessor control checks the domestic hot water inlet temperature measured by the sensor BTS (this has priority over the other parameters) and, if the measured temperature is lower than the domestic hot water set point, it will activate the domestic hot water mode automatically.

If the unit is required to operate in heating and the domestic hot water temperature is higher than the set point (there is no requirement for domestic hot water), the microprocessor control will activate the unit in heating mode. For 2-pipe models, an external 3-way valve (not provided) needs to be installed to manage DHW priority.

In models equipped with the 4-pipe option, if the unit is required to operate in cooling and domestic hot water mode the microprocessor control will activate both functions at the same time. If domestic hot water is not required, the microprocessor control will activate cooling mode only.

In stand-by mode, the controller gives the possibility to:

- ▶ display the set values
- ▶ manage alarms, their display and reports

### Reset values

Device		Set-point	Differential	Reset
Heating mode	°C	35	5	-----
Domestic hot water mode	°C	0	5	-----
Cooling mode	°C	7	5	-----
Anti-freeze thermostat	°C	5	2	Automatic
High pressure switch	Bar	45	7	Automatic
Low pressure switch	Bar	-21	10	x3 times (then manual)
Water safety valve (Present in A versions only)	Bar	6,0		Automatic

### Set points

Function		Adjustment limit	Default value
Heating set-point	°C	15-58	0
Domestic hot water set-point	°C	0-58	0
Cooling set-point	°C	6-20	7
Set point compensation	°C	0+15	10
Password			(Contact AIC)



*All set points refer to the delivered temperature (machine outlet). The unit will be stopped when the set point is reached and will start to partition at the temperature equal to the set point + differential (chiller mode) and set point - differential (heating mode).*

Dynamic Set point (Weather Compensation) Function

Dynamic set point function serves as protection from compressor working out of the unit envelope. Depending on outside weather the heat pump water outlet temperature limit changes (see **"Limits of Operation" on page G-26**).

To avoid the unit turning off when the outlet temperature is higher than limit at given air conditions, this function allows automatic adjustment of the maximum set point.



If the Energy saving mode is activated, pressing the SET button once, it allows to read the set point set by parameter. When SET key is pressed twice the bottom of the display shows the SEtTR (weather compensated set point) label that is the specific set point calculated by the controller for the measured ambient temperature condition.

*\*The function is OFF by default.*

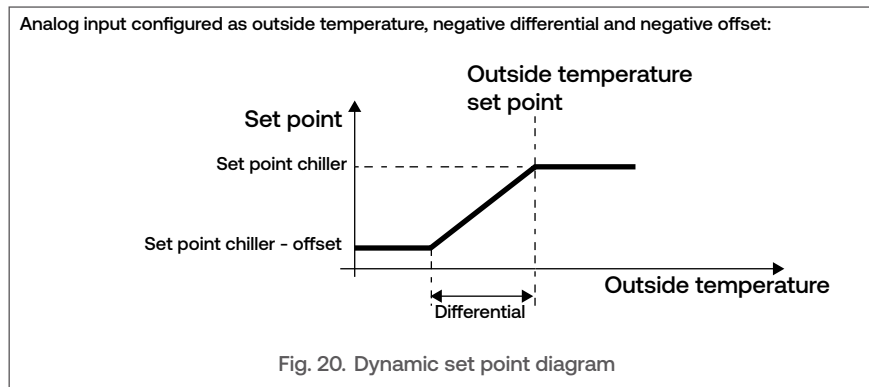

The compressor protection requires setting the dynamic set point according to the current temperature set in the main set point St04. The parameters should be adjusted to the current St04 setting according to the table.

St04	Sd02	Sd04	Sd06
58	-18	15,0	-25,0
57	-17	13,6	-23,6
56	-16	12,2	-22,2
55	-15	10,8	-20,8
54	-14	9,4	-19,4
53	-13	8,1	-18,1
52	-12	6,7	-16,7
51	-11	5,3	-15,3
50	-10	3,9	-13,9
49	-9	2,5	-12,5
48	-8	1,1	-11,1
47	-7	-0,3	-9,7
46	-6	-1,7	-8,3
45	-5	-3,1	-6,9
44	-4	-4,4	-5,6
43	-3	-5,8	-4,2
42	-2	-7,2	-2,8
41	0	-8,6	-1,4
40 or below	0	0,0	0

## ADDITIONAL INFORMATION FOR THE INSTALLER

### Operation of the Control Panel - Engineer Level



- ▷ For the meaning of the icons and functions displayed on the screen, refer to "Symbols and Functions on the Control Panel" on page G-17
- ▷ Basic operations that can be performed at end user level are described in "Operating the Controller - End User Level" on page U-30
- ▷ In some cases, a password is required to access setup or reset functions. Please contact your AIC representative for more information.

### Reading System Data - CIRC Function

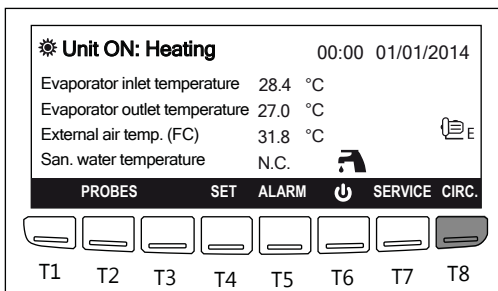

#### Depress:

T8 (CIRC) to access data related to the circuits:

- ▷ Compressor status
- ▷ Unloading status
- ▷ Evaporating-condensing probe
- ▷ Evaporating Pump status
- ▷ Condenser fan

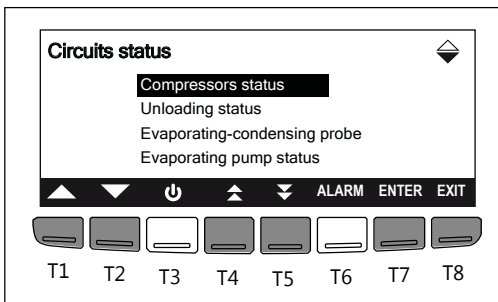

#### Depress:

T4 (▲) / T5 (▼) to scroll through the pages

T1 (▲) / T2 (▼) to scroll through the displayed lines.

T7 (ENTER) to confirm the line selection and access the line-related screen.

T8 (EXIT) to exit the menu go back to the home screen.

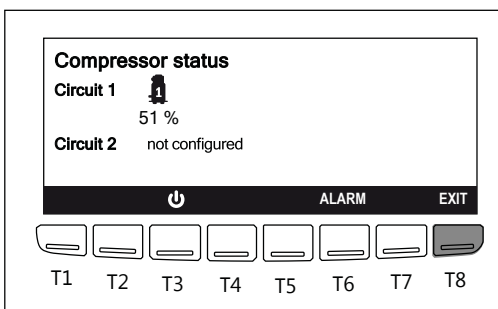

Only the Compressor Status screen is shown here as an example, but each line has its own dedicated screen.

#### Compressor Status:

- ▷ A black icon indicates an active status
- ▷ A white icon indicates an inactive status (standby)

If the compressors are used in part-load (e.g. screw compressors), an additional icon is displayed to show the level of step control.

If the compressors are of the On/Off type (Scroll) no icon is displayed next to the compressor.

T8 (EXIT) to exit the menu go back to the previous screen

Reading System Data - PROBES Function

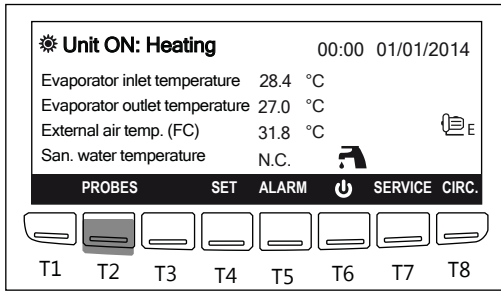

**Depress:**

T2 (PROBES) to read the data collected through the sensors installed in the system.

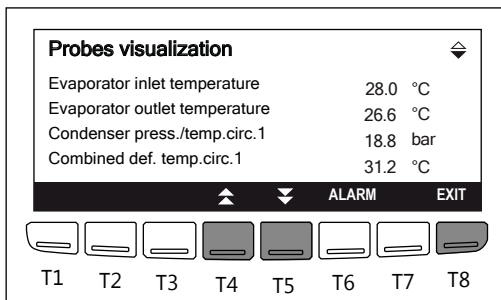

**Depress:**

T4 (▲) / T5 (▼) to scroll through the pages

T8 (EXIT) to exit the menu and return to the home screen

Accessing the Service Functions

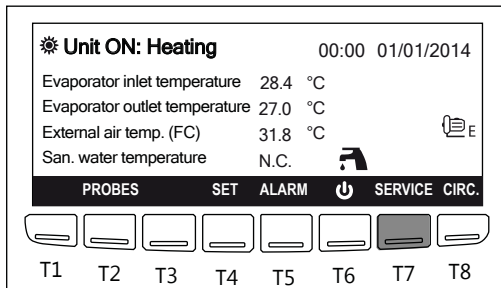

**Depress:**

T7 (SERVICE) to access the Service screen

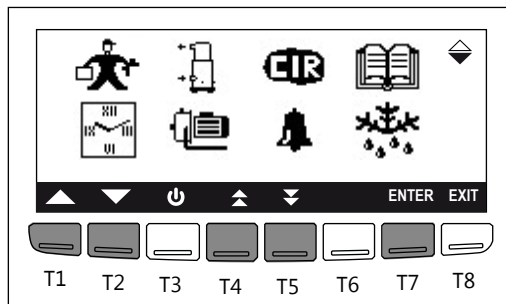

**Depress:**

T1 (▲) / T2 (▼) to scroll through the displayed icons.

T7 (ENTER) to confirm the icon selection and access the related screen.

T4 (▲) / T5 (▼) to toggle between pages 1 and 2

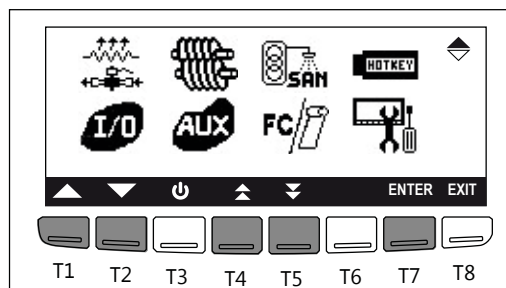

# ADDITIONAL INFORMATION FOR THE INSTALLER

## Setting the Service Parameters ( )

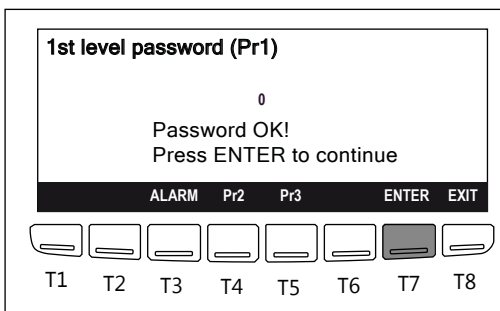
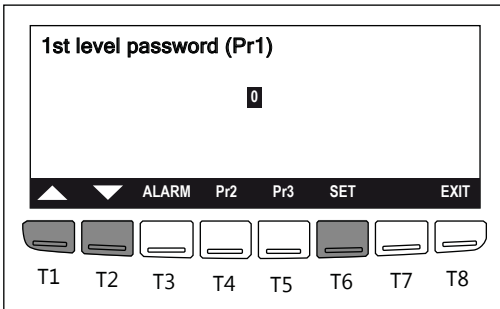

### Depress:

T1 (▲) and T6 (SET) simultaneously to set password to "1".

T6 (SET) to confirm

T7 (ENTER) to access the parameter selection screen.



*Different access levels are available that allow to change certain sets of parameters. See table below. For Service access code, please contact your AIC representative.*

Parameter Code	Meaning	Level
St	Set point	1
dP	Main visualization	Service
CF	Configuration	Service
Sd	Dynamic set	1
ES	Energy saving	1
Cr	Compressor racks	Service
CO	Compressor	Service
US	Auxiliary output	Service
FA	Fan	Service
Ar	Antifreeze	Service
dF	Defrost	Service
FS	Sanitary water	1
AL	Alarms	Service

## Service Parameters - Set Points

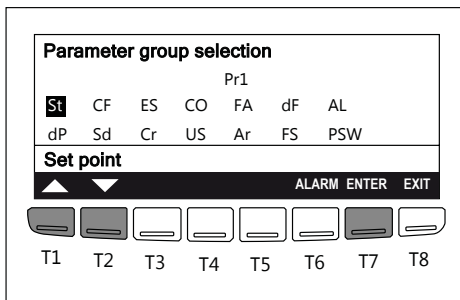

*For the related Weather Compensated function curves (Heating mode only), refer to "Dynamic Set point (Weather Compensation) Function" on page I-63.*

### Depress:

T1 (▲) / T2 (▼) to scroll through the functions, and select "St"

T7 (ENTER) to access the Set Point screen and access the following functions:

- ▶ Summer set point (St01)
- ▶ Winter set point (St04)
- ▶ Summer regulation band (St07)
- ▶ Winter regulation band (St08)

T1 (▲) / T2 (▼) to scroll through the functions

T7 (SET) to enable value change.

T1 (▲) / T2 (▼) to perform the value adjustment.

T7 (SET) to validate the change

T8 (EXIT) to exit the menu and return to the previous screen

Service Parameters - Dynamic Set Points

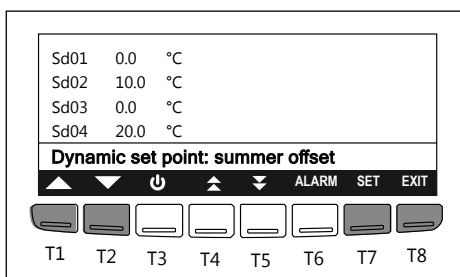
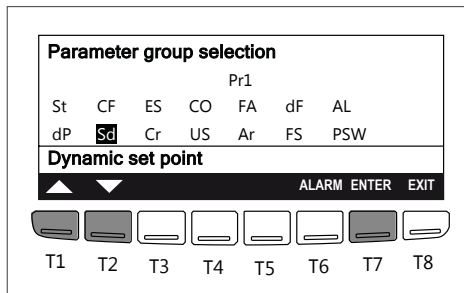

For the related Weather Compensated function curves (Heating mode only), refer to "Dynamic Set point (Weather Compensation) Function" on page I-63.

Service Parameters - Sanitary Circuit

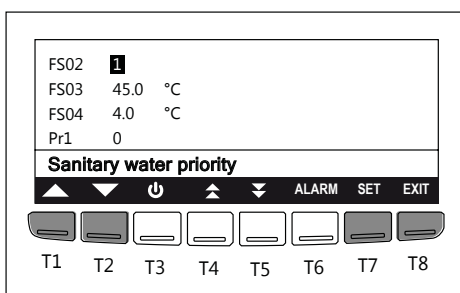
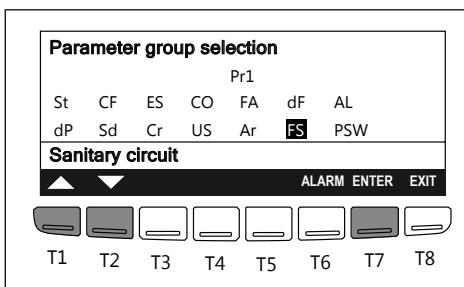

Depress:

T1 (▲) / T2 (▼) to scroll through the functions, and select "Sd"

T7 (ENTER) to access the **Dynamic Set Point** screen and access the following functions:

- › Dynamic set point: summer offset (Sd01)
- › Dynamic set point: winter offset (Sd02)
- › Dynamic set point: summer outside temp (Sd03)
- › Dynamic set point: winter outside temp (Sd04)
- › Dynamic set point: summer differential temp (Sd05)
- › Dynamic set point: winter differential temp (Sd06)

T1 (▲) / T2 (▼) to scroll through the functions

T7 (SET) to enable the value change.

T1 (▲) / T2 (▼) to perform the value adjustment.

T7 (SET) to validate the change

T8 (EXIT) to exit the menu and return to the previous screen

Depress:

T1 (▲) / T2 (▼) to scroll through the functions, and select "FS"

T7 (ENTER) to access the **Sanitary Circuit** screen and access the following functions:

- › Sanitary water priority (FS02)
- › Sanitary water set point (FS03)
- › Sanitary water proportional band (FS04)

T1 (▲) / T2 (▼) to scroll through the functions

T7 (SET) to enable the value change.

T1 (▲) / T2 (▼) to perform the value adjustment.

T7 (SET) to validate the change

T8 (EXIT) to exit the menu and return to the previous screen

# ADDITIONAL INFORMATION FOR THE INSTALLER

## Service Parameters - Energy Saving

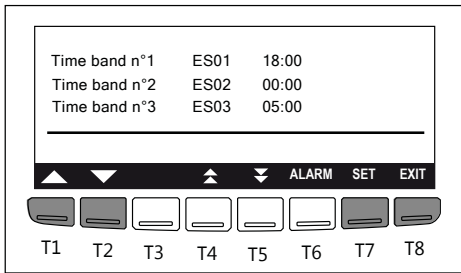
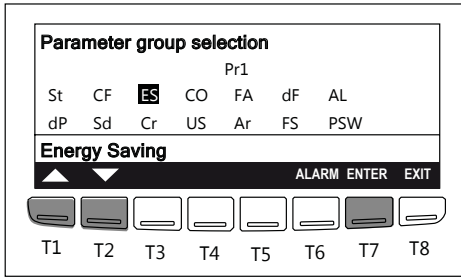

### Depress:

T1 (▲) / T2 (▼) to scroll through the functions, and select “ES”

T7 (ENTER) to access the **Energy Saving** screen.

This function allows to set the system in two different operating modes:

- ▶ **Automatic On-Off** - the unit goes On/Off according to set times.
- ▶ **Energy Saving** - two different set points can be set, one for the day and one for the night.

T1 (▲) / T2 (▼) to scroll through the functions

T7 (SET) to enable the value change.

T1 (▲) / T2 (▼) to perform the value adjustment.

T7 (SET) to validate the change

T8 (EXIT) to exit the menu and return to the previous screen



*Also refer to "Setting the Time and Date" on page U-32 for Time band parameter reading.*

Up to three time bands can be set.

Parameter code	Meaning
ES01	Start of operating range N°1 (0+2.4)
ES02	End of operating range N°1 (0+2.4)
ES03	Start of operating range N°2 (0+2.4)
ES04	End of operating range N°2 (0+2.4)
ES05	Start of operating range N°3 (0+2.4)
ES06	End of operating range N°3 (0+2.4)
ES07	Monday with energy saving time band Monday operation with automatic on/off
ES08	Tuesday with energy saving time band Tuesday operation with automatic on/off
ES09	Wednesday with energy saving time band Wednesday operation with automatic on/off
ES10	Thursday with energy saving time band Thursday operation with automatic on/off
ES11	Friday with energy saving time band Friday operation with automatic on/off
ES12	Saturday with energy saving time band Saturday operation with automatic on/off
ES13	Sunday with energy saving time band Sunday operation with automatic on/off
ES14	Increased energy saving set in chiller operation
ES15	Differential energy saving set in chiller operation

Parameter code	Meaning
ES16	Increased energy saving set in heat pump operation
ES17	Differential energy saving set in heat pump operation
ES18	Maximum unit operating time in OFF by RTC if forced into ON by button
ES19	Time band 1 DHW: start
ES20	Time band 1 DHW: end
ES21	Time band 2 DHW: start
ES22	Time band 2 DHW: end
ES23	Time band 3 DHW: start
ES24	Time band 3 DHW: end
ES25	Monday: time band selection
ES26	Tuesday: time band selection
ES27	Wednesday: time band selection
ES28	Thursday: time band selection
ES29	Friday: time band selection
ES30	Saturday: time band selection
ES31	Sunday: time band selection
ES32	Energy saving: offset DHW set point

Clock/Time Bands (  )



Also refer to "Setting the Time and Date" on page U-32.

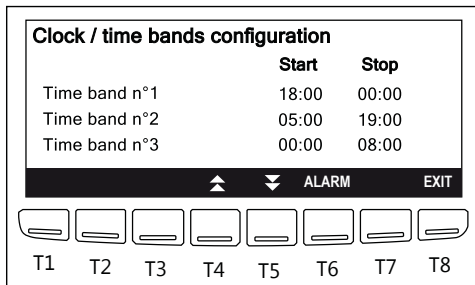
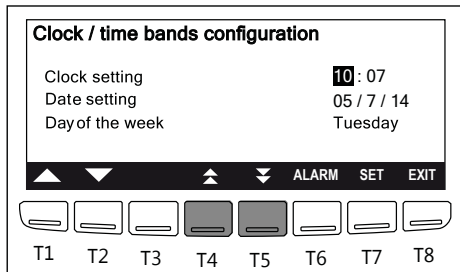

Depress:

T4 (▲) / T5 (▼) to read the info about the Energy saving, ON/OFF scheduling and time bands on other screens. Any modification is subjected to an access password. Please contact your AIC representative

T8 (EXIT) to exit the menu

Compressor maintenance (  )

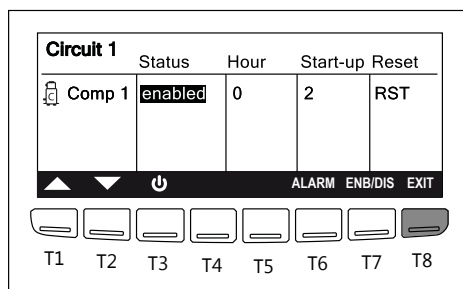
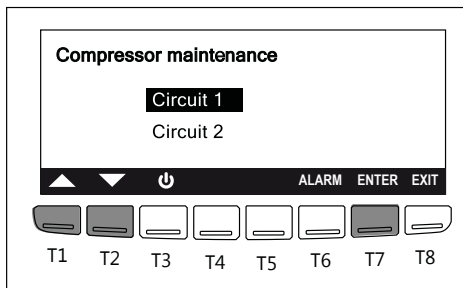

Depress:

T1 (▲) / T2 (▼) to scroll through the lines

T7 (ENTER) to access the **Circuit status** screen.



The disabling function can only be used by Service personnel

T8 (EXIT) to exit the menu and return to the previous screen

# ADDITIONAL INFORMATION FOR THE INSTALLER

## Water Pump ( )

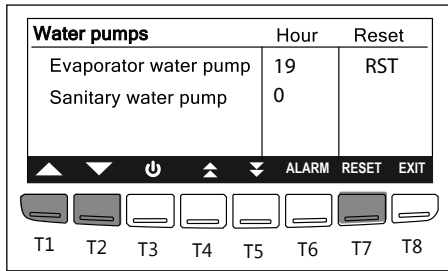

**Depress:**

T1 (▲) / T2 (▼) to scroll through the lines and display the water pumps working hours

T7 (RESET) to reset the counter.



*The Reset function can only be used by Service personnel*

T8 (EXIT) to exit the menu and return to the previous screen

## Circuit maintenance ( )

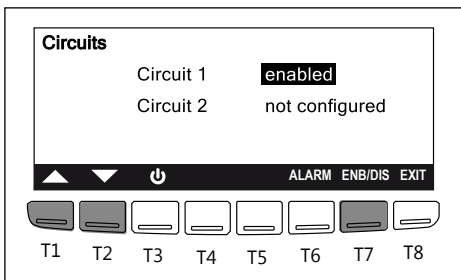

**Depress:**

T1 (▲) / T2 (▼) to scroll through the lines and display the circuits working hours

T7 (ENB/DIS) to reset the counter.



*The Enable/Disable function can only be used by Service personnel*

T8 (EXIT) to exit the menu and return to the previous screen

## Alarms ( )

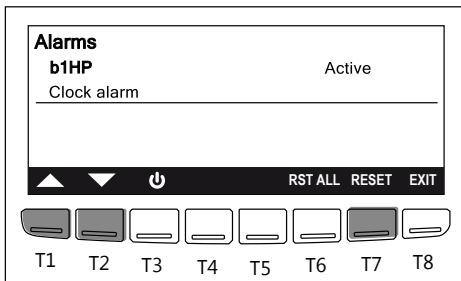

**Depress:**

T1 (▲) / T2 (▼) to scroll through the lines

T7 (RESET) to reset the alarm.



*The Reset All function can only be used by Service personnel. Also refer to "Resetting an Alarm - ALARM Function" on page U-31.*

T8 (EXIT) to exit the menu and return to the previous screen



*If an alarm buzzer is sounding, it can be stopped by pressing and releasing any of the keys.*

## Alarm log ( )

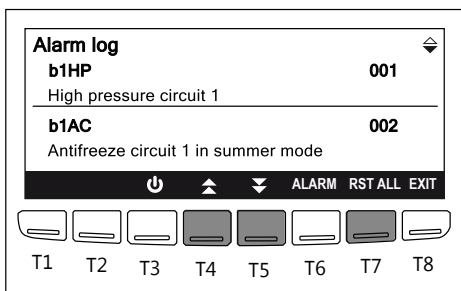

**Depress:**

T4 (▲) / T5 (▼) to scroll through the pages of the log (up to 99 errors in the log)

T7 (RST ALL) to reset the alarm.



*The Reset All function can only be used by Service personnel. Also refer to "Resetting an Alarm - ALARM Function" on page U-31.*

T8 (EXIT) to exit the menu and return to the previous screen

Defrost 

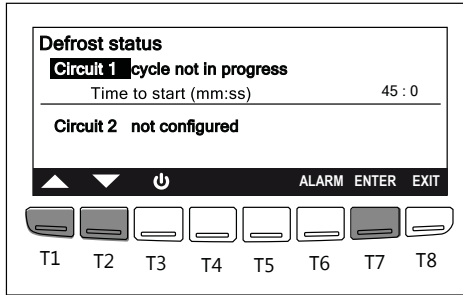

Depress:

T1 (▲) / T2 (▼) to scroll through the lines

T7 (ENTER) to access the **Defrost status** screen of the selected circuit.

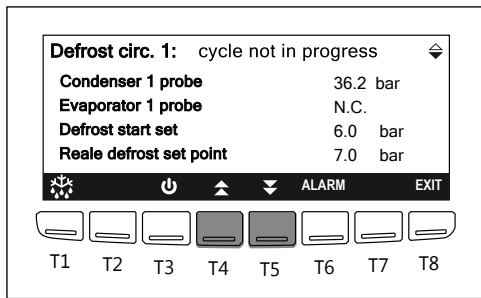

Depress:

T4 (▲) / T5 (▼) to scroll through the pages and read the parameters

T8 (EXIT) to exit the menu and return to the home screen

Electrical Heater 

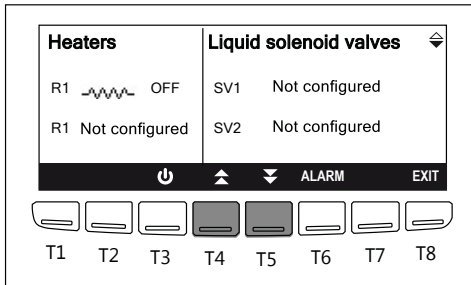

Depress:

T4 (▲) / T5 (▼) to scroll through the pages and read the parameters

T8 (EXIT) to exit the menu and return to the home screen

Input/Output Status 

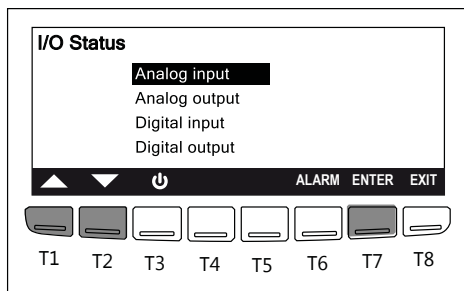

Depress:

T1 (▲) / T2 (▼) to scroll through the lines

T7 (ENTER) to access the screen of the selected line and read the parameters:

- ▶ Probes status
- ▶ Analog input and output
- ▶ Digital input and output

## ADDITIONAL INFORMATION FOR THE INSTALLER

Screw Compressor (  ) - if available

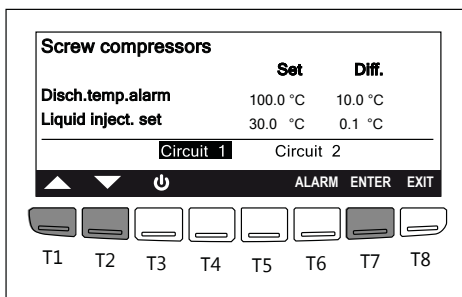

Depress:

T1 (▲) / T2 (▼) to scroll through the lines

T7 (ENTER) to access the **Screw Compressor** screen of the selected circuit.

The main screen can display the discharge temperature and the liquid injection set point.

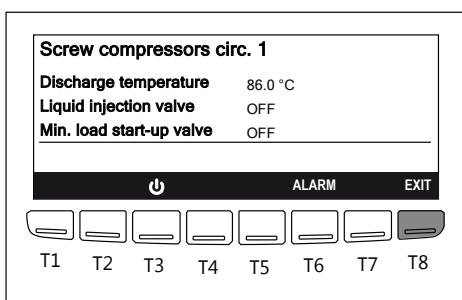

Depress:

T8 (EXIT) to exit the menu and return to the home screen

Auxiliary Output (  )

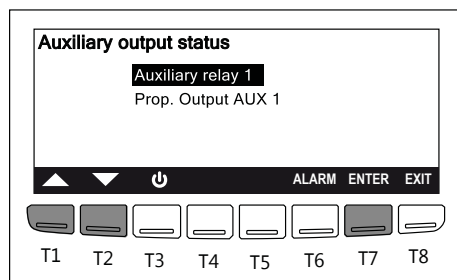

Depress:

T1 (▲) / T2 (▼) to scroll through the lines

T7 (ENTER) to access the info of the selected line.

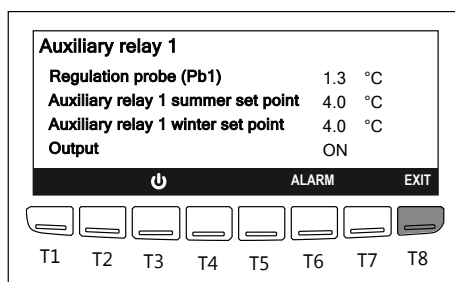

Depress:

T8 (EXIT) to exit the menu and return to the home screen

Sanitary Water (  )

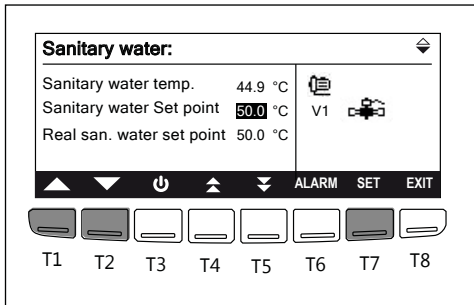

Depress:

T1 (▲) / T2 (▼) to scroll through the lines

T7 (ENTER) to access the **Sanitary water** regulation parameters.

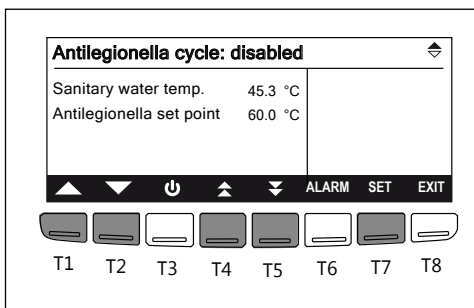

Depress:

T7 (SET) to enable the value change.

T1 (▲) / T2 (▼) to perform the value adjustment.

T7 (SET) to validate the change

T4 (▲) / T5 (▼) to scroll through the pages and read the parameters

T8 (EXIT) to exit the menu and return to the home screen

Upload/Download (  )

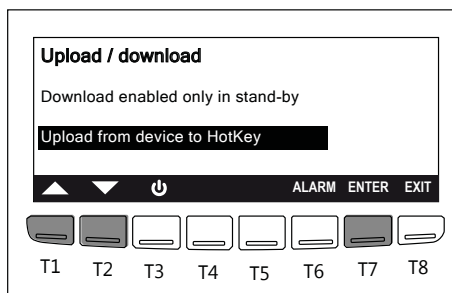

Depress:

T1 (▲) / T2 (▼) to scroll through the lines

T7 (ENTER) to activate the function.



*The Upload/Download function can only be used by Service personnel.*

Control Panel (  )

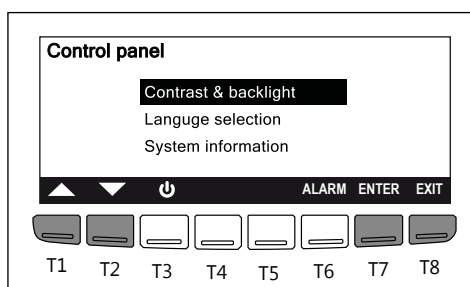

Depress:

T1 (▲) / T2 (▼) to scroll through the lines

T7 (ENTER) to activate the function.



*The Control Panel functions are already described in the end-user section, in "Control panel screen and Language Setup" on page U-33.*

## ADDITIONAL INFORMATION FOR THE INSTALLER

### Troubleshooting

#### Machine alarms

<b>Code</b>	<b>Alarm Description</b>	<b>Cause</b>	<b>Solution</b>
<b>ACF1</b> ... <b>ACF16</b>	Configuration alarm	Configuration of parameters is wrong	Change parameters to correct values, contact AIC representative if necessary.
<b>AEFL</b>	Evaporator flow alarm	No water flow in evaporator circuit	Look for clogs in circuit, check water flow sensor, check water pump performance.
<b>AEht</b>	High water temperature inlet evaporator	Water temp in water circuit too high	Check set point and parameters, waterflow, and other devices in water circuit. Check water temp sensor.
<b>AEUn</b>	Unloading signalling from high temp. of evaporator	Unload signalling from evaporator	Check set point and parameters, waterflow, and other devices in water circuit. Check water temp sensor.
<b>ALSF</b>	Phase sequence alarm	Phase order detector tripped	Check Phase order and phase order circuit.
<b>API</b> ... <b>AP8</b>	Probe alarm	Wrong wiring or configuration of probe. Damaged probe	Check probe wiring, check probe configuration parameters, check for probe damage.
<b>ASLA</b>	Failed communication with I/O expansion	Problem with communication between controller and I/O expansion	Check if lights on I/O module are on, check if link cable between modules are connected properly.
<b>AtE1</b>	Overload pump alarm of evaporator	Overload detected on waterpump	Check water circuit filters, check water pump case temperature, check current draw and compare it to value written on nameplate.
<b>AtrE</b>	Remote terminal Visograph 2.0 communication alarm	No communication with remote terminal	Check modbus connection between modules, check controller configuration, check if both modules is working.

#### Circuit alarm

<b>Code</b>	<b>Alarm Description</b>	<b>Cause</b>	<b>Solution</b>
<b>b(n)AC</b>	Anti-freeze alarm of the circuit (n) in chiller	Low water outlet temperature in chiller mode	Check if water filter is clean
<b>b(n)Ac</b>	Anti-freeze alarm signalling of the circuit (n) message in chiller		Check if outlet water temperature sensor is working
<b>b(n)AH</b>	Anti-freeze alarm signalling of the circuit (n) in heat pump	Low air outlet temperature in heat pump mode	Check for ice formation on the coil
<b>b(n)Ah</b>	Anti-freeze alarm signalling of the circuit (n) in heat pump		Check refrigerant charge Check if fan is working

**Circuit alarm**

<b>Code</b>	<b>Alarm Description</b>	<b>Cause</b>	<b>Solution</b>
<b>b(n)Cu</b>	Unloading high temp from condenser of the circuit (n)	Water/air temperature in the condenser too high	Make sure there is required flow in the water circuit Check refrigerant charge Bleed the system of any air
<b>b(n)Eu</b>	Unloading from low temp of the evaporator in the circuit (n)	Water/air temperature in the evaporator too low	Check if the coil is clean and there is sufficient airflow Check refrigerant charge
<b>b(n)ds</b>	Circuit (n) out of service	Circuit (n) disabled from keyboard	The gas circuit is restored to normal operation in the menu
<b>b(n)HP</b>	High pressure switch trip	Water high temperature External air high temperature Dirty coil Fans malfunctioning Presence of air / incondensable in the coil Excessive amount of refrigerant	Clean air heat exchanger. Check if the fans are working. Check refrigerant charge and working pressures.
<b>b(n)hP</b>	High pressure on pressure transducer of circuit (n) warning	Malfunctioning / pressure transducer out of tune	Replace pressure transducer.
<b>b(n)LP</b>	Low pressure switch trip	Water low temperature Air external low temperature Low water flow in the evaporator Dirty exchanger	Clean air heat exchanger. Check if the fans are working Check refrigerant charge and working pressures.
<b>b(n)lP</b>	Low pressure on pressure transducer of circuit (n) warning	Low refrigerant charge / empty circuit Dirty dryer filter The expansion valve does not work properly	Replace pressure transducer Replace expansion valve Replace water filter Replace filter dryer
<b>b(n)tF</b>	Fan overload in circuit (n)	Low voltage Worn or damaged electrical components Fan motor wear	Check voltage make sure its within normal values. Replace fan.

**Compressor alarm**

<b>Code</b>	<b>Alarm Description</b>	<b>Cause</b>	<b>Solution</b>
<b>C(n)dS</b>	Compressor (n) out of service	Compressor (n) disabled from keyboard	Compressor is restored to normal operation in the menu
<b>C(n)dt</b>	Compressor high discharge temperature	External air temperature high Dirty coil (in cooling mode) Fans malfunctioning Presence of air in the system Excessive amount of refrigerant	Clean air heat exchanger. Check if the fans are working. Check refrigerant charge and working pressures. Replace pressure transducer.
<b>C(n)tr</b>	Compressor(n) overload		

## ADDITIONAL INFORMATION FOR THE INSTALLER

### Default Values\*

<b>Time</b>	<b>Description</b>
<b>300 s</b>	Delay start unit after power ON
<b>180 s</b>	Minimum compressor ON time after the start-up
<b>240 s</b>	Minimum compressor OFF time after the switching off
<b>20 s</b>	ON delay time between two compressors. During this time the led of the next resource is blinking
<b>5 s</b>	OFF delay time between two compressors
<b>60 s</b>	ON compressor delay after evaporator water pump start-up
<b>60 s</b>	OFF delay evaporator water pump after the unit is turned in stand-by or OFF
<b>26,0 bar</b>	Condenser pressure start up fans
<b>18,5 bar</b>	Condenser pressure stop speed fans
<b>30 s</b>	Low pressure alarm delay from digital input after start-up compressor
<b>3</b>	Maximum number of low pressure events from digital/analogue inputs in one hour, with automatic reset
<b>30 s</b>	Evaporator Flow alarm delay from digital input after water
<b>5 s</b>	Evaporator Flow alarm delay from digital input with unit working
<b>-10° C</b>	Anti-freeze alarm chiller set point
<b>2° C</b>	Anti-freeze alarm differential for reset
<b>125° C</b>	Discharge compressor temperature alarm
<b>5,5° C</b>	User water pump activation set for antifreeze
<b>FAN SPEED CONTROL (OPTIONAL)</b>	
<b>20,0</b>	Condenser pressure start up fans
<b>32,0</b>	Condenser pressure max speed fans
<b>35%</b>	Minimum speed fans
<b>80%</b>	Maximum speed fans

\* Values for standard models only

\* The data in tables are for the basic standard unit.

<i>Indication</i>	<i>Cause</i>	<i>Solution</i>
The sight glass has a yellow colour core	Moisture present in the system	Evacuate refrigerant. Create vacuum for at least 15-30 minutes before reintroducing refrigerant into the system.
	Low level of the refrigerant charge	Perform refrigerant recovery. Recharge the system with a new refrigerant.
The outdoor unit is frozen	Anti-freeze thermostat malfunction	Make sure the thermostat is not covered by any object
	Set point is set to a higher temperature than the default (35°C)	Adjust thermostat set point back to default settings
Unit runs constantly in medium temperature mode	Heating capacity lower than the minimum	Clean finned coil surface from any debris
	Reverse cycle valve malfunction	Contact AIC representative
Unit does not switch between winter and summer mode	Thermostat malfunction	
The room temperature does not reach the set point	Unit power failure	Check if the unit is supplied with power, check if the main isolator is switched on.
	DHW production in 2-pipe system	Wait until DHW tank temperature set point is reached
The room temperature is above the set point	The room temperature settings are incorrect	Check and if needed correct: heating curve, heating mode, temperature set point, set point, time bands set.
	Unit power failure	Check if the unit is supplied with power, check if the main isolator is switched on.
No water in the tap	DHW settings are incorrect	Check and if needed correct: heating curve, heating mode, temperature set point, set point, time bands set.
	Problem with wrong cable connections or damaged electricity receivers.	Check electric connections according to electric diagram, check receivers for abnormal temperatures, or noises.
Current draw measurements incorrect		





# aicON

Connect to aicON on your computer or install the app on your smartphone or tablet to:

- › Register your product
- › Complete installation data
- › Complete commissioning data
- › Complete maintenance data
- › Order spare parts
- › and more...



[https://tracker.aicon.myaic.eu/  
dashboard/login](https://tracker.aicon.myaic.eu/dashboard/login)



AIC Europe B.V.  
Graafschap Hornelaan 163A  
NL-6001 AC Weert  
The Netherlands

[www.myaic.eu](http://www.myaic.eu)